

DELTA[®]

ROCKWELL

HOMECRAFT



HOMECRAFT POWER TOOLS

Delta Quality Makes The Difference!

Rockwell Manufacturing Company

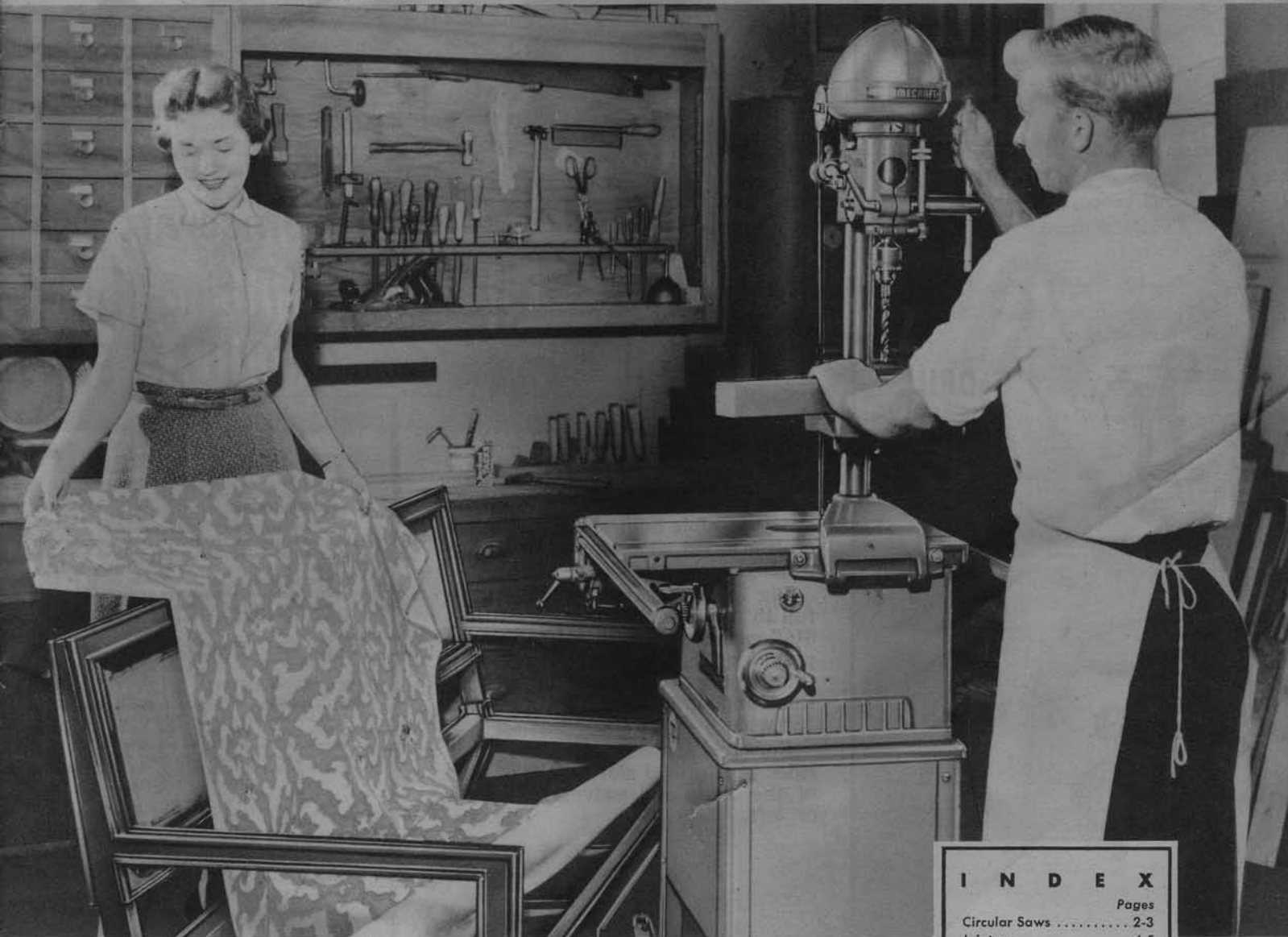

STOCKED AND SOLD BY

KARLE SAW CO. INC.
142-146 Chicago Street
BUFFALO, N. Y.

I N D E X

	Pages
Circular Saws	2-3
Jointers	4-5
Drill Press	6-7
Sander	8
Grinders	9
Band Saw	10
Scroll Saw	11
Lathe	12
Shaper	13
The Deltashop	14 to 16
Accessories	16 to 23
Motors	23
Saber Saw Attachment ..	24

WHY POWER TOOLS

Do the job faster, easier, more accurately — using the built-in skill of the tools, you give every job a professional touch.

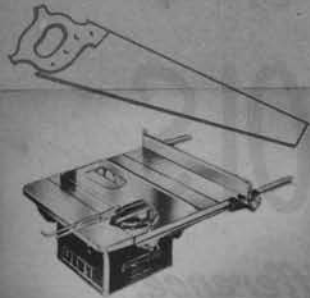

SAW

Every job begins with a saw cut . . . The Delta Circular Saw is accurate, effortless and 100 times faster.



PLANE

Planing always follows sawing . . . "POWER" planing with a Delta Jointer saves countless hours of hard labor.



DRILL

For perfect holes, properly aligned, the Delta Drill Press is fast and true where the brace-and-bit is slow and inaccurate.



SAND

Every finished job requires sanding . . . A Delta Sander will give your projects a cabinet makers finish.

Your FIRST TOOL A Circular Saw

Foundation



\$44.50

DELTA Homecraft 8" Tilting Table CIRCULAR SAW

Here's a saw on which you can do every possible homeshop sawing operation — yet, it's offered at a surprisingly low price.

Big 15" x 18" cast iron table tilts a full 45° to the right for angle cutting. 6 1/4" capacity in front of saw blade provides ample space for cross cutting. You can cut stock up to 2 1/4" thick and rip to the center of a panel 15" wide.

For cross cutting, the miter gauge rides in a milled slot on either side of the blade and swivels 60° right or left.

SPECIFICATIONS

Arbor diameter 5/8" . . . blade diameter 8" . . . maximum thickness of cut 2-1/4" . . . maximum thickness of cut at 45°, 1-9/16" . . . maximum width of dado cut 13/16" . . . table tilts to right 45° . . . table capacity in front of blade 6-1/4" . . . rips to center of 15" panel . . . table working height on steel stand 34-1/2" . . . table size 15" x 18" . . . overall dimensions 16-1/4" high by 15" wide by 21" deep . . . bronze bearings.

CATALOG LISTING

Basic Machine: 8" Tilting Table Circular Saw. Complete with rip fence, No. 34-903 miter gage, No. 325 8" combination saw blade, No. 34-904 standard table insert, No. 34-900 saw guard, splitter, anti-kick back fingers and arbor pulley. Wt., 72 lbs.
Cat. No. 34-110 . . . \$44.50

REQUIRED ACCESSORIES

V-Belt. 6 1/8" out. cir.
Catalog No. 595 . . . \$ 1.65
5" Motor Pulley. Specify 3/8" bore. Wt., 1 1/2 lbs.
Catalog No. 5500 . . . \$ 1.15
Motor. 1/2 HP Capacitor, 115 V., 60 cycle, 1725 r.p.m. 5/8" dia. double shaft, ball bearing. With switch, cord and plug, with thermal overload manual reset button. Wt., 37 lbs.
Cat. No. 62-653 . . . \$36.95

OTHER ACCESSORIES

Steel Stand, 29" high. Top 12-1/2" x 7". Wt. 29 lbs.
Cat. No. 50-329 . . . \$13.75
Switch Rod. For use with stand. Wt. 1-1/2 lb.
Cat. No. 1330 . . . \$.85
Retractable Caster Set. For steel stand No. 50-329.
Cat. No. 49-363 . . . \$9.95

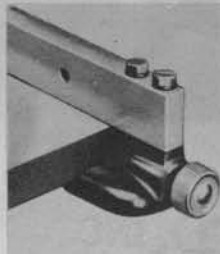

Delta self-aligning front fence clamp secures fence accurately with only one knob control.

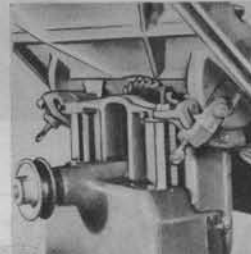

Heavy trunnions and solid under table construction—makes table surface rigid and firm.

All prices are delivered prices. Prices shown supersede all prices previously quoted. All prices subject to change without notice. The right is reserved to make changes in design or equipment at any time, without incurring any obligation to install these on machines previously sold, and to discontinue models of machines, motors or accessories at any time without notice. Any sales tax imposed will be added to the quoted prices.

(Prices Slightly Higher West of the Rockies)
Copyright — Rockwell Mfg. Co. — 1955

Other accessories for the 34-110 circular saw are listed on Pages 17 & 18.

Tool of a well planned shop

DO CURVE CUTTING ON THE CIRCULAR SAW WITH THE

New Saber Saw Attachment

Fully described on the back cover

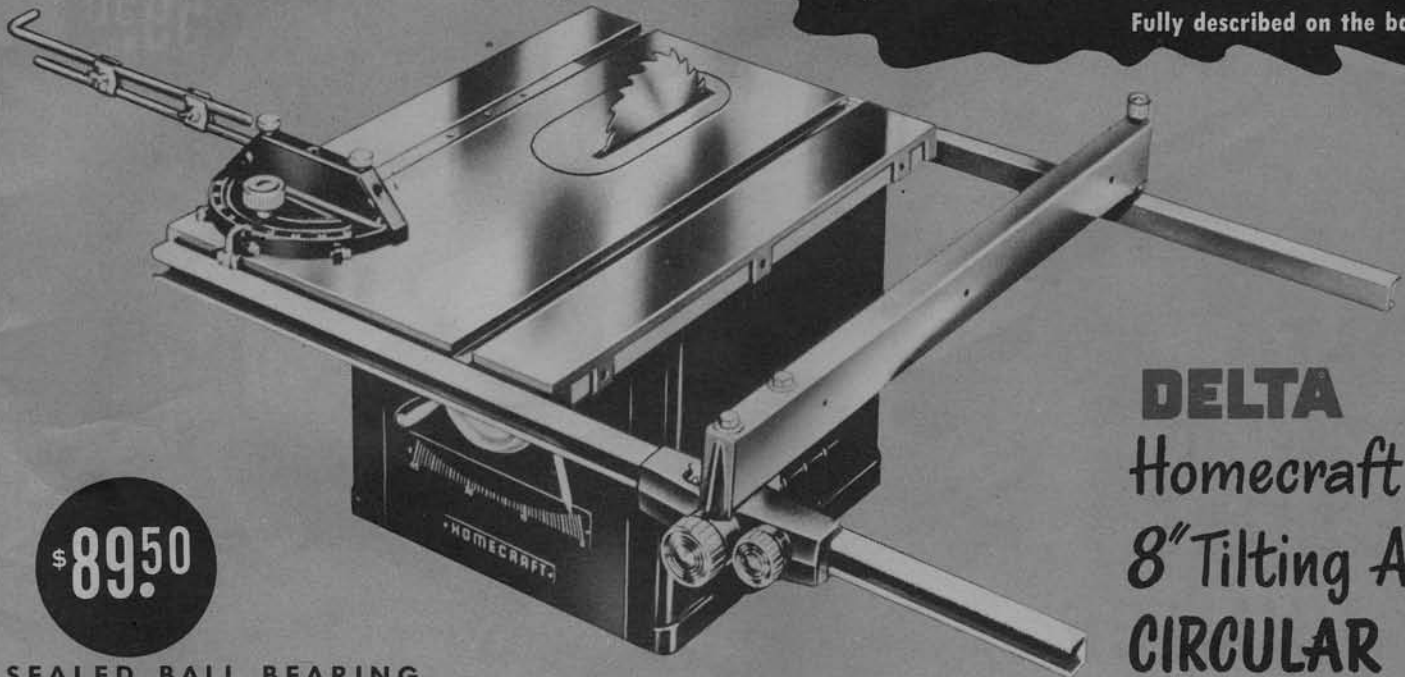

\$89.50

SEALED BALL BEARING CONSTRUCTION THROUGHOUT

DELTA Homecraft 8" Tilting Arbor **CIRCULAR SAW**

Compare this well designed, beautifully built machine with all other saws of its type and capacity—you'll agree that it is a matchless value. Compare it for big capacity, dependable accuracy, rugged construction and excellent safety features. Compare it, too, for the extraordinary number of operations it will perform.

The big table is scientifically ribbed to prevent warping; and is precision-ground to a smooth, true working surface that assures accuracy.

The tilting blade, at any angle and at any height, is always centered exactly in the slot—an exclusive Delta feature most important for maintaining accurate mea-

surements and for safety.

The arbor is supported by lubricated-for-life ball bearings; and bearing seats are precision bored.

Blade raising and tilting hand-wheels have free-turning grips and effective locking devices located conveniently. A sturdy rip fence extends the full length of the table, and has effective locking devices. Accurate positioning is easy.

Miter gauge grooves, milled simultaneously, are absolutely parallel. The calibrated miter gauge assures accurate angle cutting; and positive stops make resetting easy.

SPECIFICATIONS

Arbor diameter $\frac{3}{4}$ "...blade diameter 8"...maximum thickness of cut $2\frac{1}{4}$ "...maximum thickness of cut at 45° $1\frac{1}{8}$ "...maximum width of dado cut $1\frac{3}{8}$ "...blade tilt 45° ...table capacity in front of blade $11\frac{1}{2}$ "...rips to center of 48" panel...table working height on steel stand $34\frac{1}{2}$ "...table size 22" deep by 15" wide...table size with extensions 22" deep by 25" wide...fence $24\frac{1}{2}$ " long by 2" high...speed 3850 r.p.m. with standard 1725 r.p.m. motor (with 5" motor pulley)...overall dimensions $17\frac{1}{2}$ " high by $37\frac{1}{2}$ " wide by 32" deep...sealed, lubricated-for-life ball bearings.

CATALOG LISTING

Basic Machine: 8" Tilting Arbor Circular Saw. Complete with rip fence, rip fence guide bars, No. 864 auto-set miter gauge, No. 325 8" combination saw blade, No. 34-961 standard table insert, arbor pulley and motor cord. Wt., 103 lbs.
Catalog No. 34-500.....\$89.50

REQUIRED ACCESSORIES

$2\frac{1}{2}$ " Motor Pulley for 3450 r.p.m., $\frac{3}{4}$ H.P. motor (specify $\frac{3}{4}$ " bore). Wt., $\frac{1}{2}$ lb.
Catalog No. 5250.....\$.70
V-Belt for 3450 r.p.m., $\frac{3}{4}$ H.P. motor, 36" O.C. Wt., $\frac{1}{2}$ lb. **Catalog No. 49-152.....\$ 1.15**
Motor, $\frac{3}{4}$ HP Capacitor, 115 V., 60 cycle, 3450 r.p.m. $5\frac{7}{8}$ " dia. double shaft, ball bearing. With switch, cord and plug, with thermal overload manual reset button. Wt., 37 lbs.
Cat No. 62-253.....\$44.95

5" Motor Pulley for 1725 r.p.m., $\frac{1}{2}$ H.P. motor (specify $\frac{3}{4}$ " bore). Wt., $1\frac{1}{4}$ lbs.
Catalog No. 5500.....\$ 1.15
V-Belt for 1725 r.p.m., $\frac{1}{2}$ H.P. motor, 40" O.C. Wt., $\frac{1}{2}$ lb. **Catalog No. 49-154.....\$ 1.25**
Motor, $1\frac{1}{2}$ HP Capacitor, 115 V., 60 cycle, 1725 r.p.m. $5\frac{7}{8}$ " dia. double shaft, ball bearing. With switch, cord and plug, with thermal overload manual reset button. Wt., 37 lbs.
Cat. No. 62-653.....\$36.95

OTHER ACCESSORIES

Steel Stand, 21-1/2" high. Top 15" x 15". Wt., 50 lbs.
Cat. No. 50-810.....\$21.00
Retractable Caster Set. For steel stand No. 50-810.
Cat. No. 49-362.....\$9.95

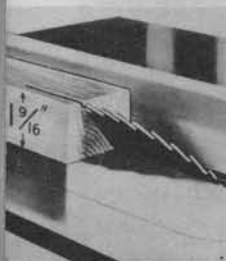

Tilting blade cross cuts $2\frac{1}{4}$ " thick... will cut to a $1\frac{1}{8}$ " capacity at full 45° tilt.

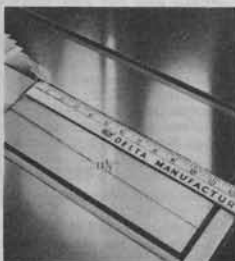

There is $11\frac{1}{2}$ " of table in front of blade—gives largest capacity work plenty of support.

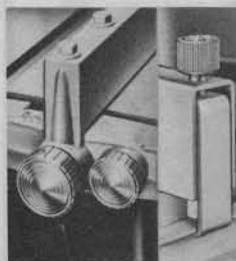

Rip fence extends entire length of the table. Locks securely on both ends.

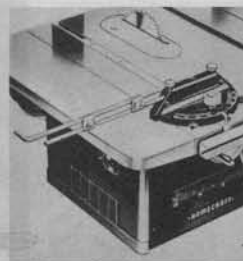

Auto-set Miter gauge assures cutting exactness. Stop rods adjustable to length.

you need a JOINTER

\$43.50

DELTA Homecraft 4" JOINTER

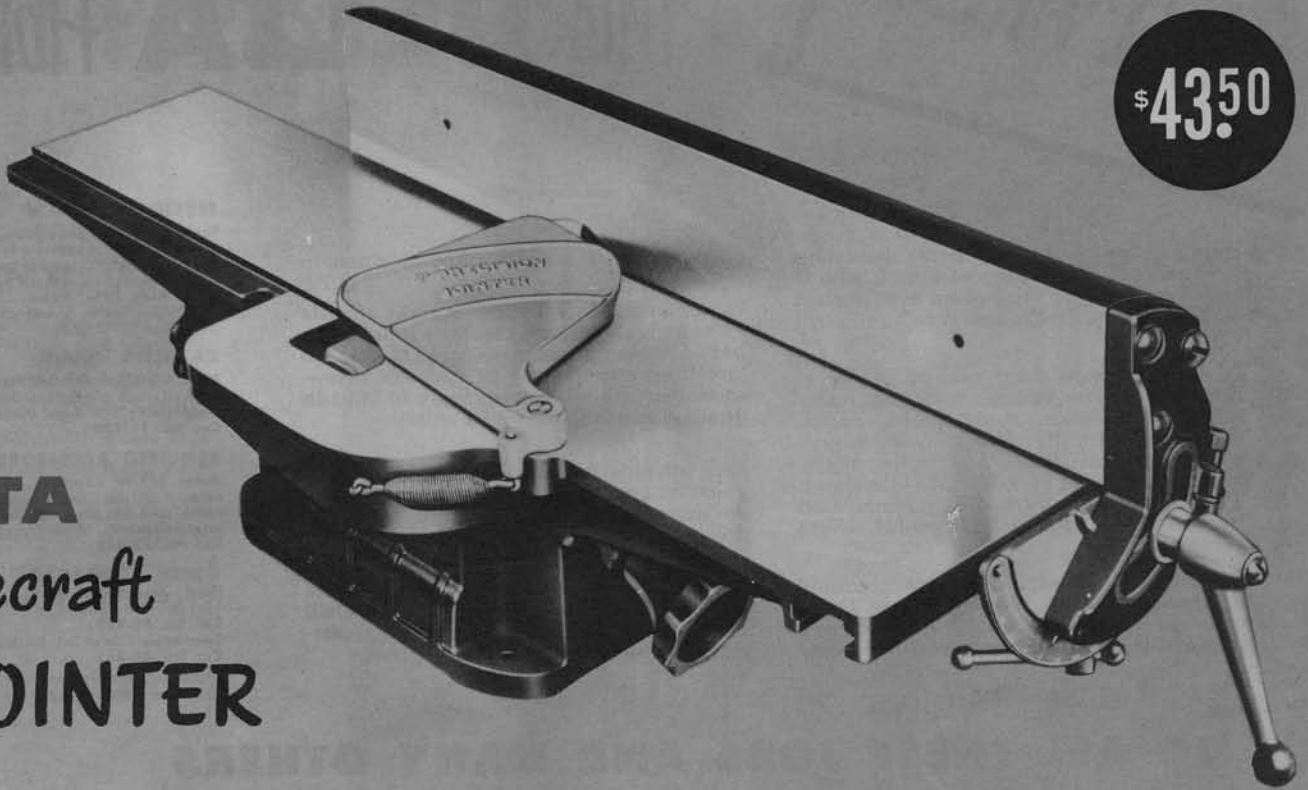

SPECIFICATIONS

Capacity 4" wide . . . rabbet 1/4" deep . . . fence tilts right or left 45° . . . adjustable stop at 90° . . . overall fence dimensions 20" long, 3" high . . . knives in cutterhead, 3 . . . table length overall 24 3/8" . . . overall dimensions 8 1/8" high, 28 1/8" long, 9 3/4" wide . . . sealed, lubricated-for-life ball bearings.

CATALOG LISTING

Basic Machine: 4" Ball Bearing Jointer. Complete with swing guard, No. 37-806 jointer head with high-speed knives and arbor pulley. Wt., 48 lbs.
Cat. No. 37-110 \$43.50

REQUIRED ACCESSORIES

V-belt. For 1725 r.p.m. motors, 59-3/8" O.C. 1 lb.
Cat. No. 49-172 \$1.50
6 1/2" Motor Pulley. With set screw for use on motor shaft. (Specify 1/2" bore.) Wt., 1 1/2 lbs.
Catalog No. 5650 \$ 1.60
Motor. 1/3 HP, split phase, 115 V., 60 cycle, 1725 r.p.m. 1/2" dia. single shaft, bronze bearing. Without switch, cord and plug. Wt., 21 lbs.
Cat. No. 60-013 \$15.95
Switch (No. 49-308), Cord and Plug (No. 49-307). For No. 60-013 motor.
Cat. No. 49-311 \$3.15
Motor. 1/3 HP Capacitor, 115 V., 60 cycle, 1725 r.p.m. 1/2" dia. single shaft, ball bearing. With switch, cord and plug, with thermal overload manual reset button. Wt., 30 lbs.
Cat. No. 62-413 \$29.95

OTHER ACCESSORIES

Steel stand. With dust chute. 29" high, top 12-1/2" x 7". Wt. 31 lbs.
Cat. No. 50-304 \$15.25
Switch Rod. For use with stand.
Cat. No. 1333 \$.85
Retractable Caster Set. For steel stand No. 50-304.
Cat. No. 49-363 \$9.95

Here's a bargain: a husky jointer with the same capacities and basic quality features as the deluxe, yet priced for economy.

The fence is a rugged casting, heavily ribbed for rigidity and finish ground for lasting accuracy. It is 20" x 3"; locks in place anywhere across the table; tilts 45° either way, and has an adjustable stop that permits return to 90° without rechecking. Easy to reach knobs, front and back, con-

trol accurate setting of the tables. Both tables are finish ground after assembly — assuring true alignment.

Solid steel cutterhead runs on sealed lubricated-for-life ball bearings; carries three high-speed-steel knives, precision ground to match and balance. Knife guard covers the knives completely — automatically moves out of the way as the work passes through.

Save with this one-motor SAW-JOINTER Combination

Here's the perfect combination for all your sawing and jointing jobs. Cut your board first on the Circular Saw and with just one step to the left, run it over the Jointer and plane it smooth.

Saw and Jointer are mounted together on a steel stand. One motor is used for both machines.

SPECIFICATIONS — See 34-110 Circular Saw and 37-110 Jointer.

CAT. LISTING—Basic Machine: Combination unit complete as shown less motor and switch rod. Unit consists of: 34-110—8" Tilting Table Circular Saw complete, 37-110—4" Jointer complete, 50-307—Steel Stand with Jointer Chute, 5500—5" Motor Pulley (specify 5/8" bore), 5650—6 1/2" Motor Pulley (specify 5/8" bore), 49-142 — V-Belt for Jointer, 49-144—V-Belt for Saw.
Wt. 200 lbs.
Cat. No. 37-510 \$115.45

REQUIRED ACCESSORIES

Motor. 1/2 HP Capacitor, 115 V., 60 cycle, 1725 r.p.m. 5/8" dia. double shaft, ball bearing. With switch, cord and plug, with thermal overload manual reset button. Wt., 37 lbs.
Cat. No. 62-653 \$36.95
Switch Rod. Catalog No. 49-380. \$.85

OTHER ACCESSORIES

Retractable Caster Set. For steel stand No. 50-307.
Cat. No. 49-362 \$9.95

Rubber Feet. For steel stand. (Note: Cannot be used with retractable caster set.)
Cat. No. 50-353 \$1.00
Other accessories for the 37-510 combination are listed on Pages 17 & 18.



Every shop
needs a
DRILL PRESS

Do more than 22 practical this **DELTA** Homecraft

Here's a "must" for any home workshop—whether it is the shop of a man who is only beginning or that of an experienced craftsman: the Delta Homecraft 11" Drill Press.

It does an astonishing variety of operations—drill, bore, counter-bore, tap, ream, spot-face, mortise, rout, shape, carve, sand, polish, buff, rabbet, flute, tenon, cut plugs and disks—and many more. Mix paint! Shine up golf clubs—or shoes! This astonishing versatility is increased by means of the many useful Delta accessories.

It's "tops" for accuracy—has precision designed and built into it, like all Delta tools. It will last a lifetime with ordinary reasonable care. In every detail, in every

ounce, it is a thoroughly fine machine.

Interchangeable spindles—a right spindle for each job, and easily installed; precision bored bearing seats—accurate fit, no loosening; dynamically balanced pulleys—these features tell convincingly of built-in quality, dependability and safety.

And all this extraordinary usefulness is yours at an attractively low price. It will do more jobs, turn out more work per dollar than any tool in the shop.

Both ways—in the unusually large amount you get and in the extremely low price you pay—the Delta Homecraft 11" Drill Press is a matchless value: a multi-purpose machine at a single-tool price.

SPECIFICATIONS

Table 8"x8" . . . base table, 6"x7 $\frac{3}{4}$ " . . . column diameter, 1 $\frac{1}{2}$ " . . . spindle to table, 11" . . . spindle to base, 14 $\frac{1}{2}$ " . . . spindle travel, 3 $\frac{3}{4}$ " . . . capacity in cast iron, 1 $\frac{1}{2}$ " . . . overall dimensions—33 $\frac{3}{4}$ " high, 11 $\frac{3}{4}$ " wide, 19 $\frac{1}{4}$ " deep . . . speeds with standard 1725 r.p.m. motor, V-belt and pulley—700, 1250, 2400 and 4700 r.p.m.

CATALOG LISTING

Basic Machine: 11" Drill Press, with 1/2" capacity Geared chuck spindle, No. 340 V-belt and No. 985 Motor pulley 1/2" bore. Wt., 77 lbs.
Cat. No. 11-120 \$54.50

REQUIRED ACCESSORIES

Motor: 1/3 HP Capacitor, 115 V., 60 cycle, 1725 r.p.m., 1/2" dia. single shaft, ball bearing. With switch, cord and plug, with thermal overload manual reset button. Wt., 30 lbs.
Cat. No. 62-413 \$29.95

OTHER ACCESSORIES

Handy Steel Stand: 31-1/4" high, Top 16-1/2" x 12-1/2". Wt., 52 lbs.
Cat. No. 50-821 \$21.75
Retractable Caster Set: For No. 50-821 steel stand.
Cat. No. 49-362 \$9.95
Other accessories for the 11-120 Drill Press are listed on pages 19 & 20

DO ALL THESE JOBS AND MANY OTHERS ON YOUR DELTA DRILL PRESS

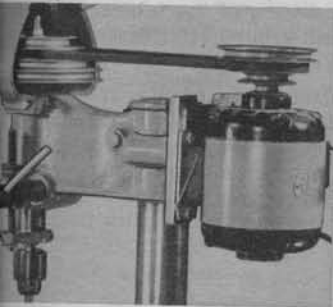

There are a full selection of speeds for drilling in wood, metal, plastic, glass and ceramics.

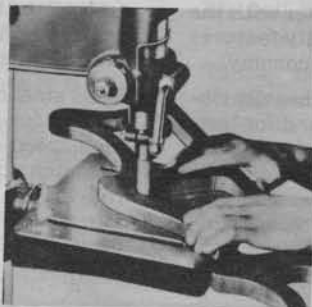

Difficult sanding of inside or intricate curves can be handled with ease for perfect edges.



Mortising is one of many useful operations . . . a necessity in making mortise and tenon joints.



Drill Press provides fast, accurate method of surface grinding in the home workshop.



Many beautiful shaped edges can be made on the drill press—using the shaper attachment.

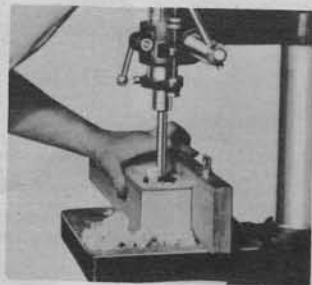

Boring in wood is practical because of the standard high speeds.

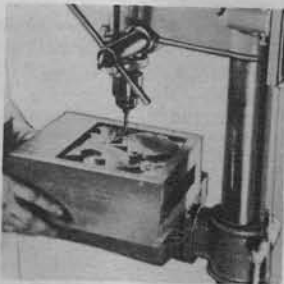

Create your own designs in relief. Built-in accuracy permits beautiful precision inlay work.

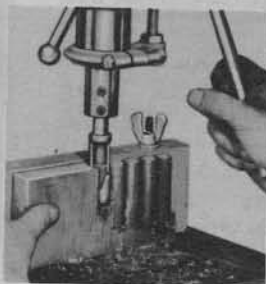

Cutting short dowels or plugs for cabinet or other work is a handy and easy operation.

DELTA QUALITY OPERATION,



A key type geared chuck is furnished as standard equipment—1/2" capacity.

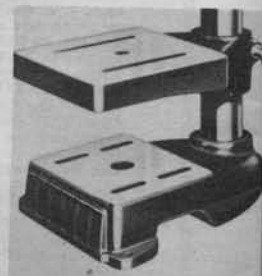

Table and base are slotted and ground to allow maximum usage of fixtures and jigs.

operations with 11" DRILL PRESS

\$54.50

JUST SOME OF
THE JOBS THIS DRILL
PRESS DOES...

- Drill
- Mortise
- Rout
- Carve
- Sand
- Shape
- Grind
- Tap
- Bore
- Polish
- Ream
- Spot Face
- Rabbet
- Cross Roul
- Flute
- Mill
- Tenon
- Buff
- Lap
- Plane
- Cut Disks
- Spin Rivets
- Mix Paint
- Use Drill Press for a
Vise
- Arbor Press

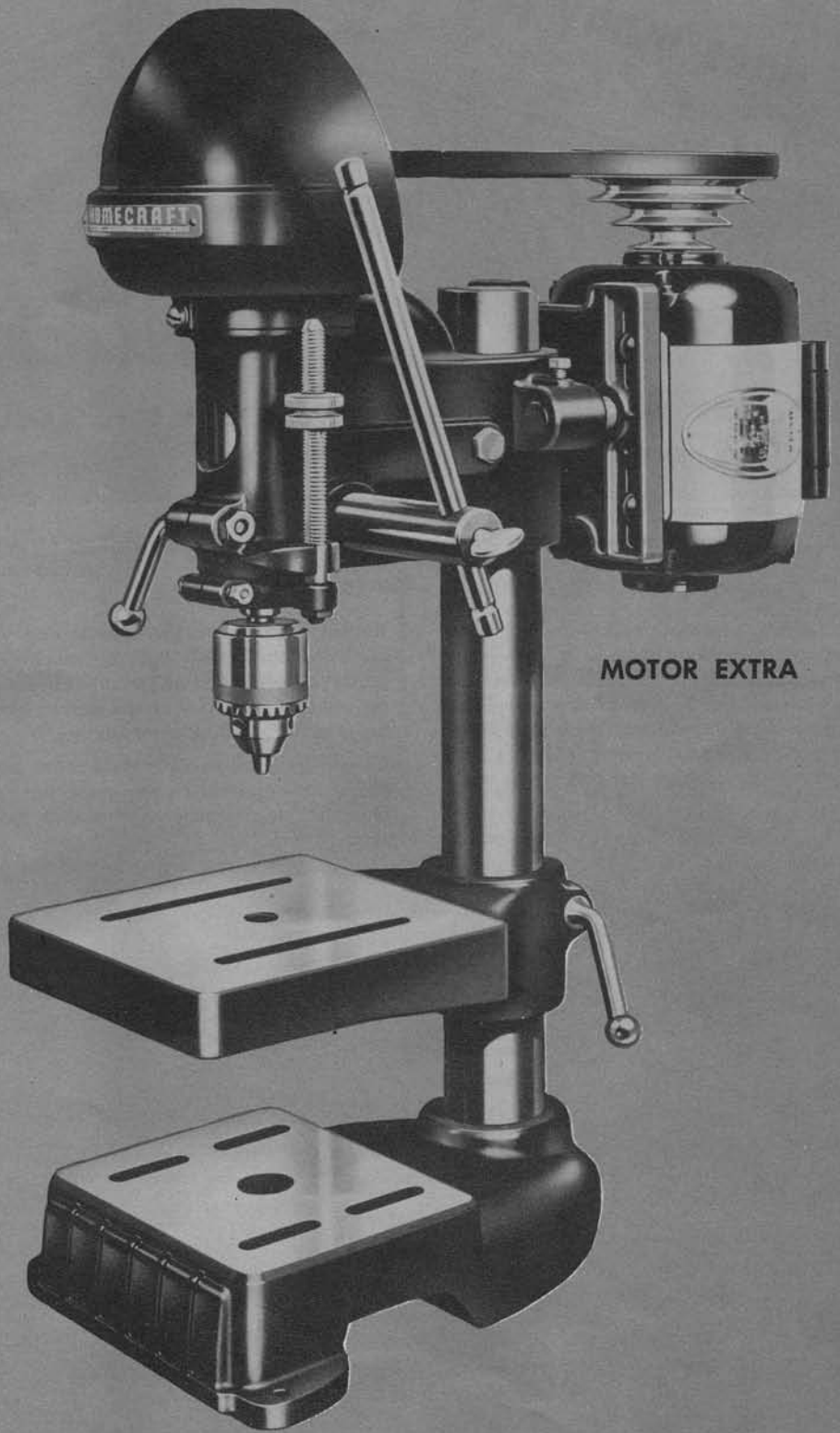

MOTOR EXTRA

STURDY CONSTRUCTION MEANS EASIER
MORE ACCURACY, LONGER LIFE.

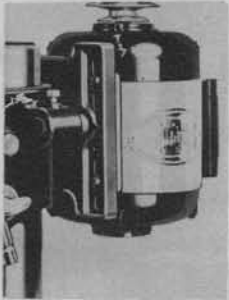

Sturdy cast iron adjustable motor bracket supports motor securely.

Quill lock and adjustable stop permit precision adjustment for repeating.

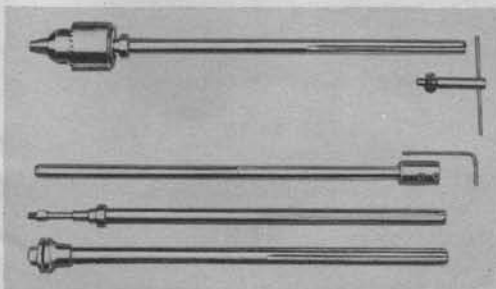

Interchangeable spindles mean fast cutting tool changes—no pulling, prying or hammering on chuck—and there's a "right" spindle for every job.

SANDER

does many jobs

\$14.95



8½" DELTA Homecraft DISK SANDER

FINISHES PROJECTS EASIER, FASTER, MORE ACCURATELY
... IS A MANY PURPOSE MACHINE

Do disk sanding . . . drum sanding . . . horizontal
drilling . . . grinding . . . buffing . . . brushing

Put a fine, professional-looking finish on straight, curved or angular surfaces—on wood, plastics, ivory and non-ferrous metals—with this 8½" Homecraft Disk Sander. You'll save the time and labor that tedious hand sanding requires and have a better-looking finished job as well. In addition, this sander makes a handy multi-purpose tool for your home shop.

Mount a chuck on the spindle and you have a horizontal drilling machine—mount a Delta Sanding Drum for finishing curved surfaces—mount the proper wheel for grinding, buffing or brushing.

Unusually low-priced, it does more jobs, dollar for dollar, than any multi-purpose machine we've seen. Add one to your shop today!

SPECIFICATIONS

8½" disk diameter . . . 1½" wide . . . 8⅞" high . . .
10" deep . . . table 4⅞" x 9⅞" . . . table tilts 35° toward disk, 45° away from disk.

CATALOG LISTING

Basic Machine: 8-1/2" Disk Sander, complete with sanding disk, sample disk adhesive, and pulley. Wt., 19 lbs.

Cat. No. 31-200 \$14.95

REQUIRED ACCESSORIES

- 2½" Motor Pulley. Specify ½", bore. Catalog No. 5250 \$.70
- V-Belt. 47⅞" O.D. Catalog No. 453 \$ 1.45
- Motor 1/3 HP Capacitor, 115V., 60 cycle, 1725 r.p.m. 1/2" dia. single shaft, ball bearing. With switch, cord and plug, with thermal overload manual reset button. Wt., 30 lbs. Cat. No. 62-413 \$29.95
- Motor, 1/3 HP, split phase, 115 V., 60 cycle, 1725 r.p.m. 1/2" dia. single shaft, bronze bearing. Without switch, cord and plug. Wt., 21 lbs. Cat. No. 60-013 \$15.95
- Switch (No. 49-308), Cord and Plug (No. 49-307). For No. 60-013 motor. Cat. No. 49-311 \$3.15
- Miter Gauge. Precision built—makes accurate sanding easy. Catalog No. 31-804 \$ 2.95

ACCESSORIES FOR DISK SANDING

- Garnet Paper Sanding Disks, Coarse, No. 1½ grade (1 doz.). Catalog No. 46-815 \$ 2.30
- Garnet Paper Sanding Disks, Fine, No. 0 Grade (1 doz.). Catalog No. 46-817 \$ 1.70
- Disk Adhesive (1 lb. bar). Catalog No. 49-503 \$.95

ACCESSORIES FOR DRUM SANDING

- 3" x 3" Sanding Drum. Wt., 2 lbs. Catalog No. 830 \$ 4.75
- 1¾" dia. x 2" Drum. Wt., 1¾ lbs. Catalog No. 835 \$ 3.10
- For Sanding Sleeves, see Drill Press Accessories, Page 19.

ACCESSORIES FOR DRILLING

- Keyless Chuck. 0-½" capacity. Fits any ½" shaft. Catalog No. 120 \$ 3.75
- For Router Bits and Machine Auger Bits, see Drill Press Accessories, page 19.

ACCESSORIES FOR GRINDING, BUFFING, BRUSHING

- Arbor. Needed to adapt ½" shaft to grinding wheels, buffing wheels, wire wheels. Right hand thread only. Catalog No. 49-118 \$ 1.70
- Wire, Fiber, Grinding, Buffing wheels and other accessories for 31-200 sander are listed on Page 22.

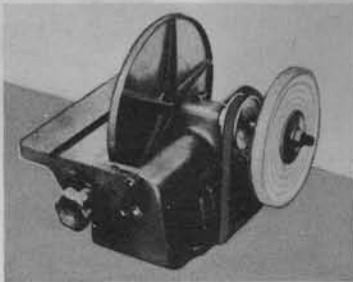
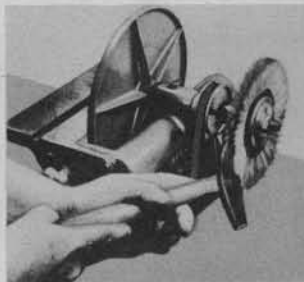
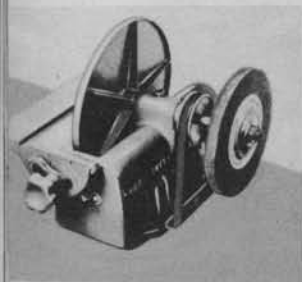

The grinding wheel is used to keep a sharp keen edge on all your chisels, knives and bits.

The fiber brush removes rust from tools and household equipment, too . . . quickly and easily.

For buffing, simply mount proper wheel . . . put a high gloss finish on metal, wood, plastics and ivory.

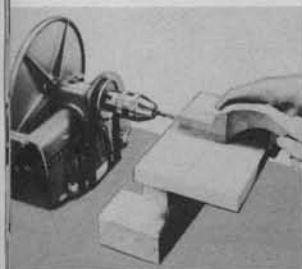

Horizontal drilling, using a keyless chuck . . . allows you to end-drill extremely long pieces.

Plain and compound miters are easy with the miter gauge. Accuracy makes it an ideal homeshop tool.

A drum sander mounted on the spindle, puts a clean, smooth, even edge on all your irregular work.

**A
GRINDER**
is a "must"
for every shop

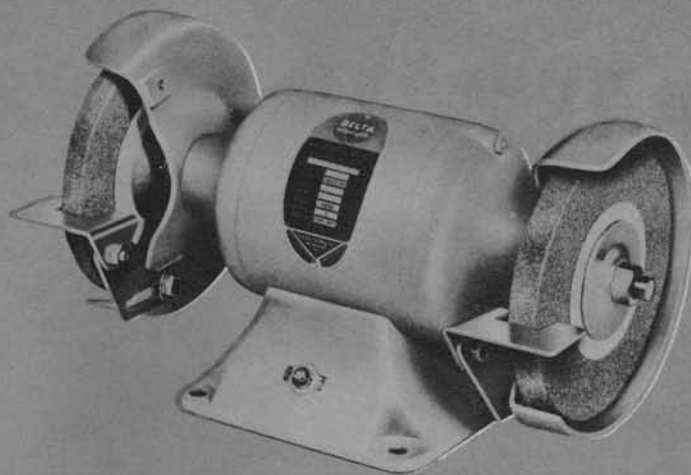

\$39.95

This **DELTA**
Homecraft **BENCH GRINDER**

KEEPS ALL YOUR TOOLS SHARP AND BRIGHT

- TWO 6" GRINDING WHEELS
- SAFETY WHEEL GUARDS
- ADJUSTABLE TOOL REST
- 1/4 H.P., 3450 R.P.M. MOTOR

Keeping a keen edge on cutting tools is essential to good work. This sturdy, carefully engineered Homecraft Bench Grinder is ideal for that purpose. You'll do expert tool grinding—and the time saving is enormous.

In addition, with the accessories in the handy kit, you can do buffing, remove rust and scale of all kinds with wire brushes, and do general cleaning with fiber brushes. A complete unit, the Homecraft Bench Grinder is ready to go to work for you today.

SPECIFICATIONS

Two 6" grinding wheels 5/8" wide, 1/2" bore (60 grit and 46 grit)... on-off toggle switch... 8-ft.—three conductor rubber covered cord and attachment plug.

CATALOG LISTING

Basic Machine: As illustrated with 1/4 H.P., 115 V. single phase, 60 cycle, 3450 r.p.m. motor, wheel guards and adjustable tool rests. Wt., 36 lbs.

Catalog No. 23-600 \$39.95

REQUIRED ACCESSORIES

Eye shields. Easily attached to No. 23-600 grinder. **Cat. No. 23-800** \$3.75

Other accessories for 23-600 grinder are listed on Page 22.

DELTA Homecraft **BASIC HEAD UNIT**

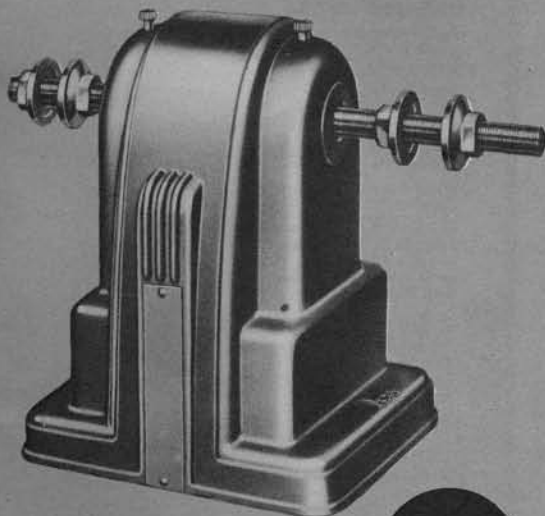

\$8.45

A basic head unit to take attachments for sharpening tools, polishing metals, etc. Here's the fast, easy way to polish silver, faucets, lamp bases, electrical outlets, golf clubs—as well as keeping tools keen. Shine your shoes, too.

Handy and portable, it can be driven from its own motor or another machine. On the basic head unit you can mount wheels for several operations: right-hand or left-hand grinding, buffing, cleaning or combinations—you select the one you need.

It's a versatile time and work-saver.



Left hand unit with grinding wheel only.



Right hand unit with grinding and buffing wheels.

SPECIFICATIONS

Close-grained, grey iron casting with long-wearing bronze bearings... 1/2" dia. shaft extends 2 1/8" on left, 3 3/4" on right... shafts threaded and fitted with large flange nuts.

CATALOG LISTING

Basic Machine: Buffing and Grinding Head. Complete with belt. Drives from either bottom or rear. Wt., 10 lbs.

Catalog No. 23-603 \$ 8.45

REQUIRED ACCESSORIES

3" Motor Pulley. Use with 1725 r.p.m. Motor. 1/2" bore. Set screw for attaching to motor shaft. **Catalog No. 5300** \$.80

Motor, 1/3 HP, split phase, 115 V., 60 cycle, 1725 r.p.m. 1/2" dia. single shaft, bronze bearing. Without switch, cord and plug. Wt., 21 lbs.

Cat. No. 60-013 \$15.95

Switch (No. 49-308), Cord and Plug (No. 49-307). For No. 60-013 motor. **Cat. No. 49-311** \$3.15

Left Hand Grinding Unit. Consists of left hand guard and tool rest with mounting screws and two large flanges and nut for clamping wheel to arbor. Wt., 5 lbs.

Cat. No. 23-606 \$2.25

Right Hand Grinding Unit. Consists of right hand guard and tool rest with mounting screws and two large flanges and nut for clamping wheel to arbor. Wt., 5 lbs.

Cat. No. 23-607 \$2.25

Wire, Fibre, Grinding, Buffing wheels and other accessories for 23-603 Basic Head are listed on Page 22.

**WHEN YOU
WANT TO
CUT CURVES**

DELTA Homecraft 10" BAND SAW

... for inside contour cuts and big-capacity straight line sawing—such as ripping thick stock, resawing and jobs other saws can't handle

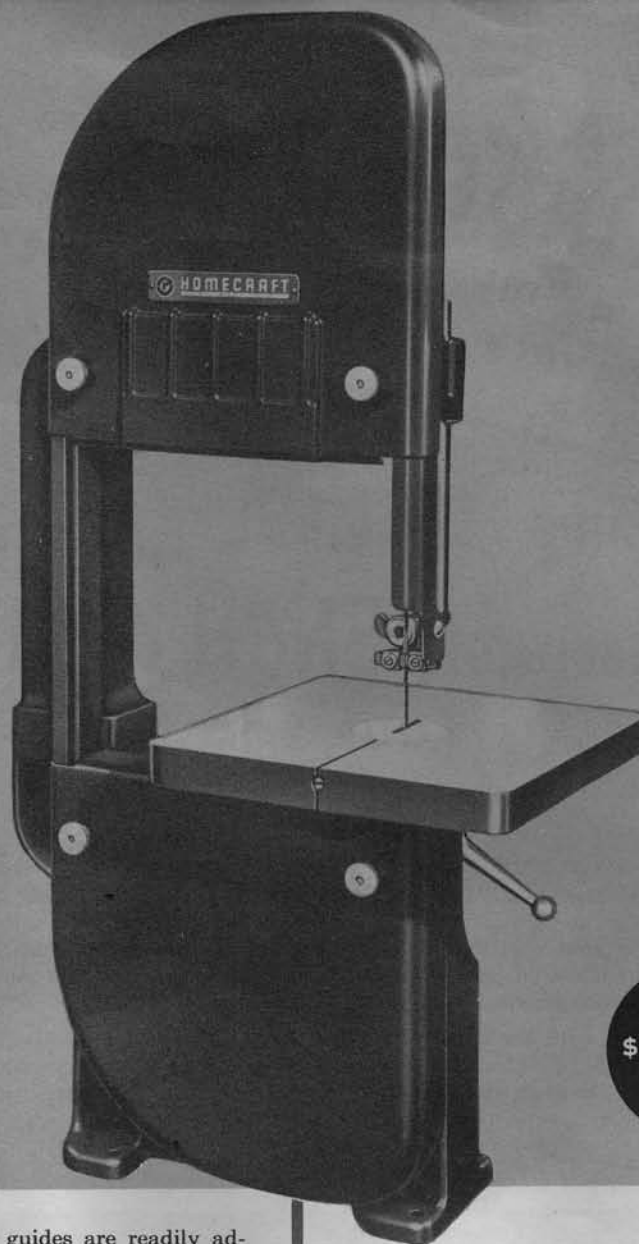

\$54.50

This saw "belongs" in every completely equipped shop, and will prove to be one of its most useful tools. It is ideal for ripping thick stock, up to 6", and for cross-cutting and miter-cutting stock that is too thick or too wide for the circular saw.

The rugged frame is cast in only two sections; the hollow cast upper arm prevents all springing and twisting. The heavily ribbed, finish-ground table supports the work; and a removable aluminum insert prevents damage to blades. The table tilts 45° for angle cutting, and an accurately graduated scale shows the exact degree of tilt. A leveling stop screw makes it easy to level the table quickly and accurately.

Upper and lower guides are readily adjustable. The ball bearing blade support is independently adjustable. All adjusting mechanisms are simple and fool-proof.

Upper wheel runs on needle bearings, the lower wheel on two oil-impregnated bronze bearings. Wheel tension and tracking adjustments are in handy position on upper arm. Wheels and blades are completely guarded. Magnesium spoke wheels are light in weight, accurately balanced—reduces flywheel action, machine can be stopped quickly.

Compare this saw, point by point, with others.

SPECIFICATIONS

Capacity—blade to frame 9 $\frac{3}{4}$ ", under guide 6 $\frac{1}{2}$ "
... speed—with 1725 r.p.m. motor, 2400 feet per minute ... dimensions—height 32 $\frac{1}{4}$ ", width 11 $\frac{3}{8}$ ", depth 18". ... table 10"x10". ... table tilt 45° ... blade length 71 $\frac{3}{4}$ ".

CATALOG LISTING

Basic Machine: 10" Band Saw. Complete with wheel guard No. 28-803 $\frac{1}{4}$ " blade and 5" arbor pulley. Wt., 70 lbs.

Catalog No. 28-110.....\$54.50

REQUIRED ACCESSORIES

V-Belt, 58 $\frac{3}{4}$ " outer circumference.
Catalog No. 560.....\$ 1.60

Motor Pulley, 2 $\frac{3}{4}$ ". Specify $\frac{1}{2}$ " bore.
Catalog No. 5275.....\$.75

Motor, 1/3 HP Capacitor, 115 V., 60 cycle, 1725 r.p.m. 1/2" dia. single shaft, ball bearing. With switch, cord and plug, with thermal overload manual reset button. Wt., 30 lbs.
Cat. No. 62-413.....\$29.95

Motor, 1/3 HP, split phase, 115 V., 60 cycle 1725 r.p.m. 1/2" dia. single shaft, bronze bearing. Without switch, cord and plug. Wt., 21 lbs.
Cat. No. 60-013.....\$15.95

Switch (No. 49-308), Cord and Plug (No. 49-307). For No. 60-013 motor.
Cat. No. 49-311.....\$3.15

OTHER ACCESSORIES

Handy Steel Stand, 29" high, Top 12-1/2" x 7". Wt. 29 lbs.

Cat. No. 50-329.....\$13.75

Switch rod for use with stand.
Cat. No. 1334.....\$.85

Retractable Caster Set. For No. 50-353 steel stand.
Cat. No. 49-363.....\$9.95

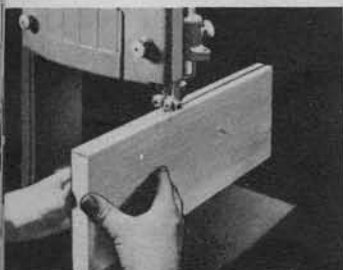

Big capacity cut! Up to a full 6" in hardwood. Cuts wood and plastic smoothly, rapidly, easily ... straight line or curve.

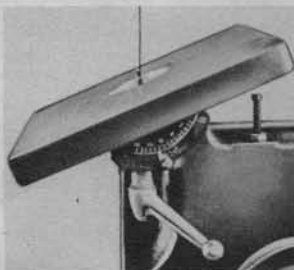
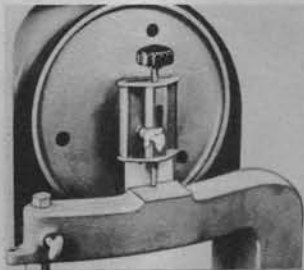

Table tilts for combination curves, miters or bevels. Table is big, 10"x10", yet rigid. Handy gauge tells angle or tilt at a glance.



Wheel tensions and blade tracking adjustments on upper arm casting. Handy accurate means of correcting alignments of blade, ... keeping correct tension at all times.

Other accessories for the No. 28-110 Band Saw are listed on page 22.

DELTA Homecraft 16" SCROLL SAW

For interior curves,
inlays and marquetry
and intricate patterns impossible to
cut with other saws

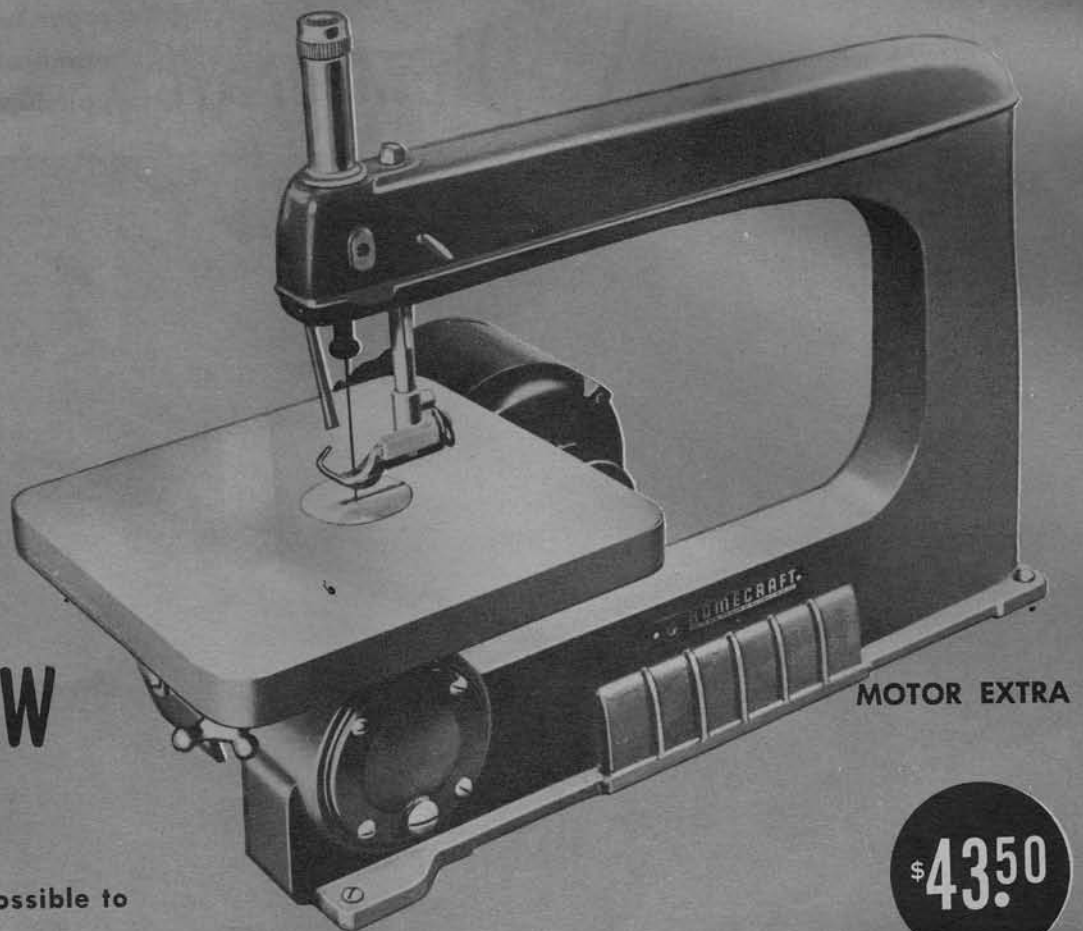

\$43.50

Gone are the old-fashioned slowness and long hours of painstaking care, once needed to turn out worthwhile looking projects in your home workshop. Instead, with the saw-blade making 1275 cutting strokes per minute, you turn out accurate, professional-looking work in an incredibly short time.

Many types of sawing not possible with other saws can be done with this machine—it's easy to use—very safe—ideal for any beginner—man, woman or youngster.

The bronze bearings are constantly lubricated by the splash system from the crankcase. The lower chuck is of uni-

versal type to fit all types of blades, files and sanding attachments. Continuous air flow from a blower in the head keeps the cutting line free from sawdust. The table tilts for angle cutting. Guides are fully adjustable. Upper and lower chucks rotate 90°, for unlimited length of cut.

A single casting forms the base and arm—strong, rigid, accurately machined. The pulley guard, easily removable, provides full protection.

A thorough examination of this fine saw shows instantly how far ahead it is of other comparably priced saws. It's truly a great value.

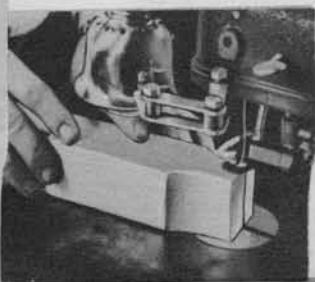

Big capacity cut! Up to 2" in wood, cuts to the center of a 32" panel. Variable speed pulley allows work in wood, metal or plastic!

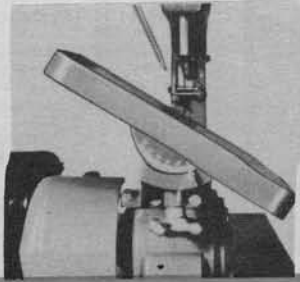

Big 11"x11" table tilts 45° to the right and 15° to the left for all angle cutting. Guides are fully adjustable.



Both upper and lower chucks rotate a full 90°—you can make a straight-line, continuous cut as long as you need.

SPECIFICATIONS

Cuts to center of 32" panel . . . thickness of cut, 2" in wood . . . cutting strokes per minute, with 3" motor pulley for wood, plastics, etc., 1275—with 2" motor pulley for light metals, 800 . . . table size 11"x11" . . . table tilts 45° right, 15° left . . . overall length 26 3/4", width 12 1/2", height 20 1/4" . . . upper and lower chucks turn 90° for unlimited length of cut.

CATALOG LISTING

Basic Machine: 16" Scroll Saw, Complete with No. 5400 3/8" bore arbor pulley, four universal saw blades and pulley guard. Without motor, Wt., 72 lbs. Catalog No. 40-110 . . . \$43.50

REQUIRED ACCESSORIES

3" Motor Pulley for cutting wood. 1/2" bore for recommended motors. Catalog No. 5300 . . . \$.80

2" Motor Pulley for cutting metal. 1/2" bore for recommended motors. Catalog No. 5200 . . . \$.70

Motor. 1/3 HP, split phase, 115 V., 60 cycle, 1725 r.p.m. 1/2" single shaft, bronze bearing. Without switch, cord and plug. Wt., 21 lbs.

Cat. No. 60-013 . . . \$15.95

Switch (No. 49-308), Cord and Plug (No. 49-307). For No. 60-013 motor.

Cat. No. 49-311 . . . \$3.15

Motor. 1/3 HP Capacitor, 115 V., 60 cycle, 1725 r.p.m. 1/2" dia. single shaft, ball bearing. With switch, cord and plug, with thermal overload manual reset button. Wt., 30 lbs.

Cat. No. 62-413 . . . \$29.95

V-belt. For use when bench mounted, 39-7/8" O.C. Cat. No. 387 . . . \$1.25

OTHER ACCESSORIES

V-belt, 54 1/8" outer circumference. For use with steel stand when motor mounted below on shelf.

Cat. No. 520 . . . \$ 1.50

Steel Stand. 33" x 7" table, 31 1/2" high. Wt., 55 lbs.

Cat. No. 50-716 . . . \$19.50

Switch Rod. For use when motor on stand shelf.

Cat. No. 1330 . . . \$.85

Retractable Caster Set for No. 50-716 steel stand.

Cat. No. 49-363 . . . \$ 9.95

V-belt. 64-15/16" O.C. For use with steel stand (Motor mounted behind saw).

Cat. No. 618 . . . \$ 1.65

Other accessories for the No. 40-110 Scroll Saw are listed on page 18.

**TWO
FINE TOOLS**
for fine cabinet work

DELTA Homecraft 11" LATHE

... for wood turning, metal turning, taper turning, dowels, spirals and numerous EXTRA jobs such as polishing, buffing and many more

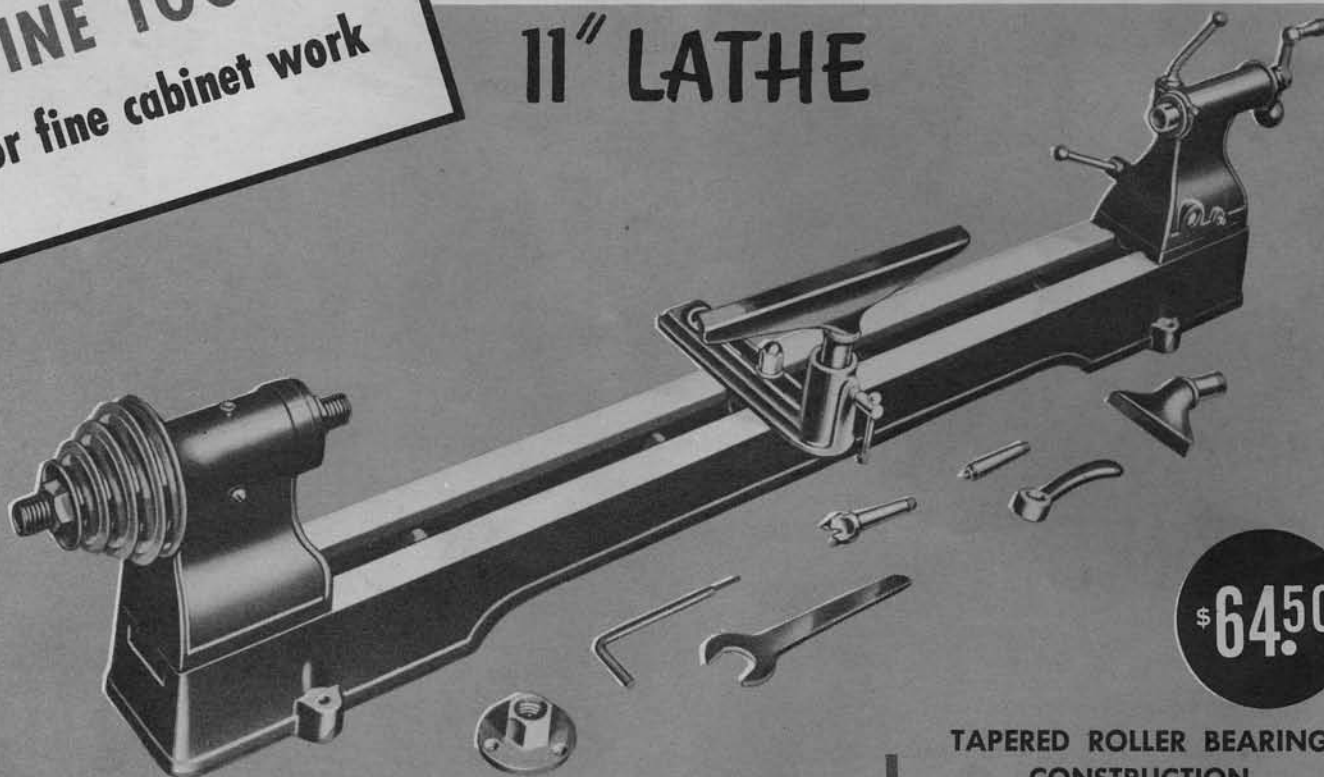

\$64.50

**TAPERED ROLLER BEARING
CONSTRUCTION**

Here's a tool so simple, so easy to operate that anyone can do good turning—and have a wonderful time doing it. In fact, even if it's your first try, you'll probably do a good job. It's a husky tool, built to do professional looking work and to give you top quality at a low price.

Only the Delta Homecraft 11" Lathe gives you all these important advantages:

- Fine grained, grey iron bed—heavily ribbed for rigidity and strength • Ways accurately ground • Timken Tapered Roller Bearings, with adequate thrust and load capacity, used to carry spindle
- No. 2 Morse taper centers and other attachments for quick changes • Heavy, non-jamming thread on both ends of spindle • Double row index mechanism built into headstock, invaluable for

quick division of spindle or face plate work • $\frac{5}{8}$ " hole through headstock, for repetition work on rods and dowels • Graduated tailstock sleeve and adjustable pointer for convenience in drilling work held in chuck • No wrench required to lock tailstock to bed—ball lever at rear, locks or unlocks tailstock in one movement • Set-over tailstock permits accurate alignment of centers to compensate for any slight unevenness of bench surface • Slide rest and other metal-working attachments available at moderate cost, permitting lathe to be used for light metal work, such as armature turning.

A complete line of Delta accessories increase the usefulness of your Delta Homecraft Lathe.

SPECIFICATIONS

Speed with 1725 r.p.m. motor—930, 1400, 2140, 3200 r.p.m. ... swings over bed, 11" ... between centers, 37" ... dimensions—overall length 56½", width 10½", height 12" ... accurately ground ways both front and back, 1½" wide ... spindle 1" ... spindle hole $\frac{3}{8}$ " ... spindle thread 1" diameter, 8 acme threads per inch.

CATALOG LISTING

Basic Machine: Timken bearing lathe No. 2 morse taper spindle, No. 933 drive center, No. 934 cup center, No. 936 3" face plate, No. 690 4" tool support, No. 692 12" tool support No. 941A tool support base, tool support wrench, Allen wrench, and spindle wrench. Wt., 77 lbs.
Cat. No. 46-230 \$64.50

REQUIRED ACCESSORIES

Motor. 1/2 HP Capacitor, 115 V., 60 cycle, 1725 r.p.m. 5/8" dia. double shaft, ball bearing. With switch, cord and plug, with thermal overload manual reset button. Wt., 37 lbs.
Cat. No. 62-653 \$36.95

Motor. 1/3 HP Capacitor, 115 V., 60 cycle, 1725 r.p.m. 1/2" dia. single shaft, ball bearing. With switch, cord and plug, with thermal overload manual reset button. Wt., 30 lbs.
Cat. No. 62-413 \$29.95

Motor pulley. Specify 1/2" or 5/8" bore, 2 lbs.
Cat. No. 932 \$2.25
V-belt. 61-11/16", O.C. For use with lathe, 1/2 lb.
Cat. No. 588 \$1.65

Wood Turning Chisels—Made of special, high grade alloy steel. Fitted with extra long hard-wood handles, 1-1/4" x 10-1/2", overall length 17".

Cat. No.	Description	
121	1" Skew	\$ 2.50
122	3/4" Gauge	2.50
123	1/4" Gauge	2.10
124	1/2" Skew	1.75
125	1/8" Parting	2.00
126	1/2" Gauge	2.25
127	1/2" Spear Point	1.75
128	1/2" Round Nose	1.85
130	Set of 8 Chisels	16.00

Other lathe accessories are listed on Page 20.

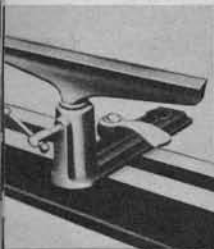

Tool support operates quickly and smoothly, is universal in action; locks securely with lever. Always maintains its accuracy—never slips.

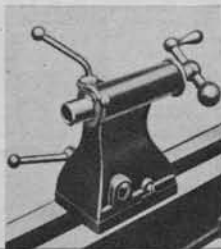

Tailstock locks to bed in one quick movement. Has set-over provision for constant alignment. Tailstock sleeve is graduated for drilling work.

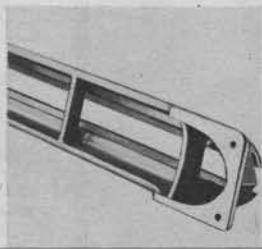

For strength and rigidity this cast iron lathe bed can't be beat. Heavily ribbed bed provides solid base for headstock, tailstock, tool support and accessories.

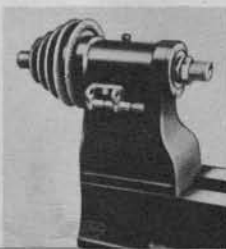

Self-indexing headstock has built-in indexing device in cone pulley for dividing face plate work and for spacing cuts in fluting and reeding.

DELTA Homecraft SHAPER

... make cope and reverse mouldings, sash mouldings, door mouldings, brick moulds, base moulds and many more—quicker, faster, safer

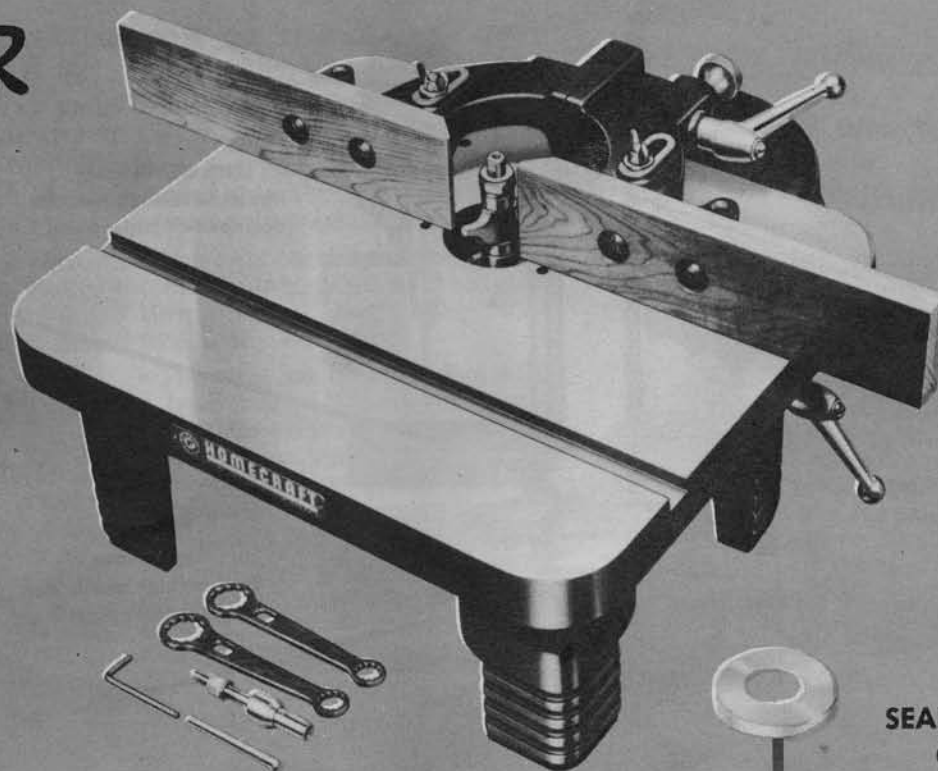

\$69.50

SEALED BALL BEARING
CONSTRUCTION

When it comes to producing professional-looking work, there's nothing like this shaper. You can make all the shapes and moulds you see on expensive furniture and perform any number of home maintenance jobs as well. It's *the* tool for the hobbyist.

This compact ball bearing reversible spindle shaper has built into it all the excellent features experienced shopmen want, and all the sturdy quality for which Delta tools are famous. It is generally acknowledged to be the best shaper for home shops, and has thoroughly demonstrated that it is the safest.

The fence is 25 1/4" long when fully extended. It is completely adjustable, front,

back and sideways, and both sides adjust independently.

The table's big 15 1/2"x18" work surface is finish ground for accuracy, and has a 3/8"x3/4" groove for sliding jig and miter gauge. The table is heavily ribbed underneath for extra rigidity and firmness. Interchangeable spindles, 5/16" and 1/2" diameters, run in sealed-for-life ball bearings. Conveniently located controls raise and lower the spindle. Shaper is reversible and runs at 9000 r.p.m. for smooth, clean work. Belt and pulley are effectively guarded.

For versatility, strength, safety and low cost, this shaper is an extraordinary value.

SPECIFICATIONS

Height 7 1/2", width 25 1/4", depth 24" ... table size 15 1/2"x18" ... fence length—each side, 11 1/2" ... speed 9000 r.p.m. ... spindle travel 7/8" ... spindle carried in double-sealed ball bearings ... spindle height lock ... tapered starting pin ... legs drilled for mounting reversing switch.

CATALOG LISTING

Basic Machine: Ball Bearing Reversible Homecraft Shaper. Complete with No. 982 shaper fence, 5/16" and 1/2" spindles (with the 5/16" spindle, use same 3-lip cutters as are used with 11" Homecraft Drill Press; with 1/2" spindle, use No. 1343 3-knife Safety Cutter-head and same knives as used on moulding cutter-head attachment for circular saw), table insert, starting pin, belt and pulley guards, motor bracket, spindle pulley and wrenches. Wt., 48 lbs.
Catalog No. 43-110.....\$69.50

REQUIRED ACCESSORIES

Stub Spindle. With screw and Allen wrench for counterbored 3-lip cutters.
Catalog No. 1190.....\$ 3.40
5-3/8" Motor Pulley. With key and set screws; 1/2" bore. For No. 62-213 motor.
Catalog No. 43-803.....\$ 2.70
V-Belt. 30" O.C. For No. 62-213 motor. Wt., 1/2 lb.
Catalog No. 49-105.....\$ 1.15
Motor 1/2 HP Capacitor, 115V., 60 cycle, 3450 r.p.m. 1/2" dia. single shaft, ball bearing. With cord and plug. Wt., 26 lbs.
Cat. No. 62-213.....\$39.95
Reversing and On-and-Off switch. For 62-213 motor, with connected 4-wire cord for any standard, split-phase or capacitor motor.
Cat. No. 49-316.....\$11.50

OTHER ACCESSORIES

Handy Steel Stand. 26-1/2" high. Top 12-7/16" x 16-7/16". Wt. 51 lbs.
Cat. No. 50-305.....\$21.00
Retractable Caster Set. For No. 50-305 steel stand.
Cat. No. 49-362.....\$9.95

Other shaper accessories are listed on Pages 21 and 22.

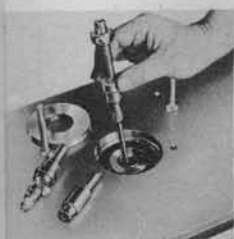

Interchangeable spindles permit use of wide variety of cutters, also stub spindle for cope cuts on sash and door, and cabinet work.

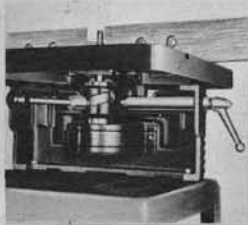

Spindle height adjustment under front of table makes accurate height adjustments easy; locks quickly in place with convenient lock handle.

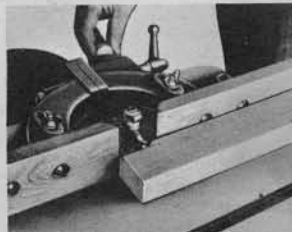

Both halves of fence adjustable through one control. Endwise adjustment permits cutter opening to be made small as possible—an added safety feature.



Another Delta "extra"—safety guards completely cover motor belt, motor pulley and spindle pulley. Operator gets maximum protection at all times.

The DELTASHOP... the

Save space, time, money...
with this compact, one stand,
one motor combination of the
most-used power tools!

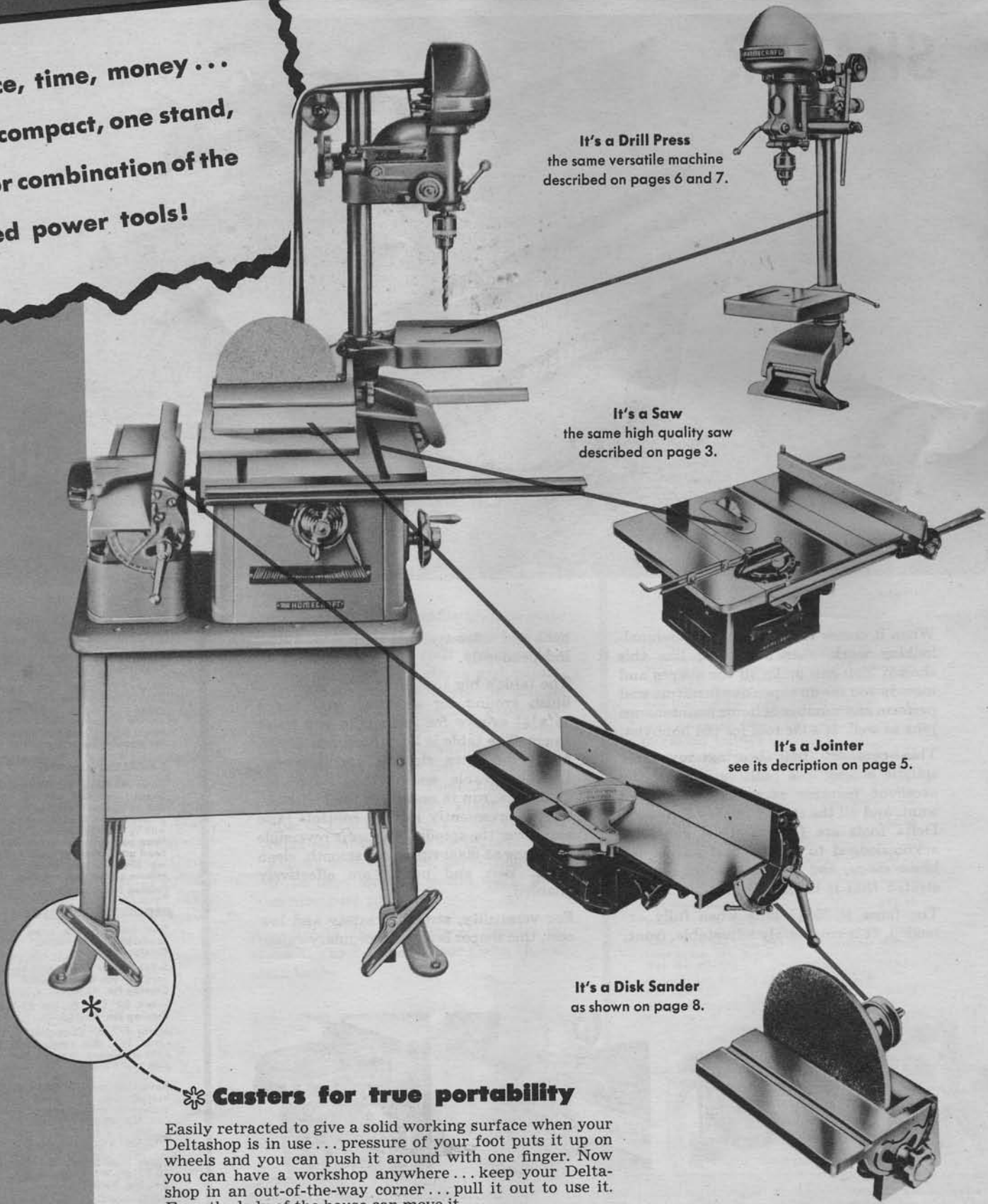

It's a Drill Press
the same versatile machine
described on pages 6 and 7.

It's a Saw
the same high quality saw
described on page 3.

It's a Jointer
see its description on page 5.

It's a Disk Sander
as shown on page 8.

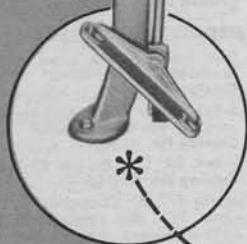

*** Casters for true portability**

Easily retracted to give a solid working surface when your Deltashop is in use... pressure of your foot puts it up on wheels and you can push it around with one finger. Now you can have a workshop anywhere... keep your Delta-shop in an out-of-the-way corner... pull it out to use it. Even the lady of the house can move it.

RETRACTABLE CASTER SET Catalog No. 49-360.....\$12.50

Perfect Combination Tool!

NEW 5th TOOL! THE CURVE CUTTING Saber Saw Attachment

NEVER BEFORE A COMBINATION OF TOOLS LIKE THIS

- At last here is an appliance for the man of the house... all you need to do your own furniture building and home improvement and repair... does 95% of all workshop jobs.
- The only combination of power tools on which you have a choice of purchasing plans—you can buy it complete (pre-assembled) or a tool-at-a-time as your budget permits.
- An engineered combination of high quality, big capacity Delta Homecraft Power Tools... not a collection of attachments.
- Fits anywhere... occupies only a 3 foot square of floor space... with the new casters you can keep it anywhere... roll it out to

use... roll it back out of the way when finished.

- The only combination of power tools you can separate into individual units... later, as your interests and your shop grows.
- The only combination of power tools built around a sturdy 8" tilting arbor saw... the basic tool in any workshop.
- The only combination tool with a true jointer. When you saw a board, the next natural step is to plane a true square edge... the jointer is always ready—no adjustments are necessary.
- Examine it... try it... check it against all other combination units and you'll see... It's the Delta Quality That Makes The Difference.

Quickly Installed on Your Deltashop Saw



This is one of the most exciting tools developed for do-it-yourself enthusiasts. In a matter of seconds you can convert your Deltashop into an efficient big capacity machine to do intricate curve cutting, sanding and filing operations.

See back cover for a complete description.

ONLY WITH THE DELTASHOP CAN YOU DO ALL THESE JOBS

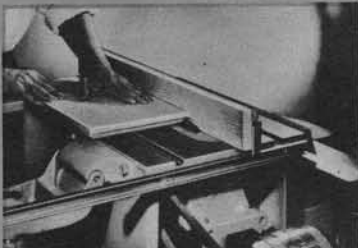

Make countless attractive mouldings by means of the moulding cutterhead attachment.

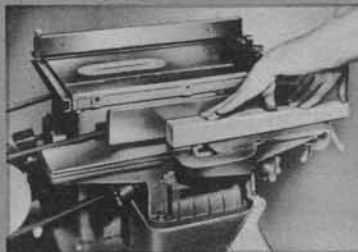

Taper cuts are easy: simply adjust the two table-sections to provide the wanted degree of taper.



Cut rabbets for drawers, shelves, etc. — true smooth, in one quick pass. Saves countless hours and hard labor.

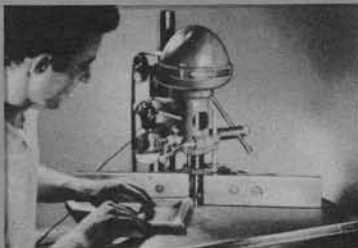

Make picture frames, shaped table edges, ornamental mouldings.

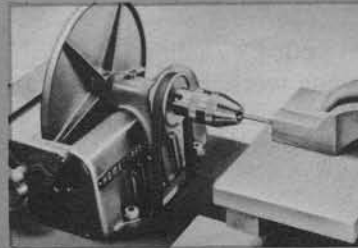

You can even do horizontal drilling with the Deltashop Sander.



Cut box joints with a dado head.

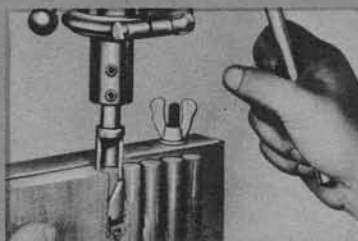

Cut your own plugs and dowels.



Finish curved surfaces with a horizontal sanding drum.

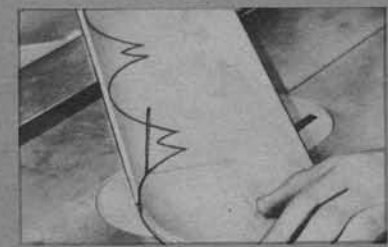

With the new Saber Saw attachment you can even do curve cutting.

See page 16 for information on ordering the Deltashop either complete (pre-assembled) or on the easy Tool-at-a-Time Plan.

Here's How To Order Your Economical **DELTA'SHOP**

You can order your Deltashop complete, pre-assembled and enjoy its full benefits now, or you can order on the revolutionary Delta-shop Tool-at-a-Time Plan. This special plan enables you to start with the basic saw and stand and add the remaining tools as your budget permits.

THE DELTA'SHOP COMPLETE (PRE-ASSEMBLED)

Catalog listing: Deltashop, consisting of No. 34-500 8" Tilting Arbor Saw, No. 37-110 4" Jointer, No. 37-113 Jointer Raising Block, No. 11-130 Drill Press (complete with No. 49-179 Belt), No. 49-189 Saw Arbor Pulley, No. 31-200 Disk Sander, No. 31-201 Sander Base (with No. 281 Belt), No. 50-308 Steel Stand, No. 49-188 Motor Belt and Pulley Group (consisting of No. 5225 Saw Pulley, No. 49-152 Saw Belt, No. 49-182 Jointer Pulley and No. 410 Jointer Belt).

Includes No. 62-253 3/4 H.P., 115 Volt, 60 Cycle, 3450 r.p.m. sealed-for-life ball bearing motor.

Catalog No. 34-535 \$278.95

THE DELTA'SHOP TOOL-AT-A-TIME PLAN

PACKAGE #1 Saw and Stand **CAT. NO. 34-532** . . . \$109.80
Also order the motor described above. **Cat. No. 62-253** . . . \$44.95

PACKAGE #2 The Jointer **CAT. NO. 37-114** . . . \$ 49.15

PACKAGE #3 The Drill Press **CAT. NO. 11-130** . . . \$ 57.50

PACKAGE #4 The Sander **CAT. NO. 31-202** . . . \$ 17.55

The necessary belt and pulley groups are included in the packages as well as all parts required for assembly.

For information on ordering the curve cutting Sabre Saw attachment please see the back cover.

DELTA'SHOP CONVERSION KITS

Special conversion kits enable you to mount your Deltashop Drill Press separately under its own power as your workshop grows, or to put together your own compact Deltashop if you already own some of the basic tools. For full details see Page 22.

SAW-JOINTER COMBINATION



An ideal tilting arbor Saw and Jointer combination unit can be formed by ordering Package #1 and #2 of the Deltashop Tool-at-a-Time Plan and Cat. No. 62-253 motor. All the motor belts and pulleys are included with the packages.

PACKAGE #1 . . The Saw and Stand **CAT. NO. 34-532**

PACKAGE #2 The Jointer **CAT. NO. 37-114**

With DELTA Accessories Every Machine Becomes a Many--Purpose Unit

Delta accessories broaden the usefulness of Delta Homecraft Tools far beyond that of other makes — each machine becomes a multi-purpose unit. They enable you to do literally hundreds of extra jobs, greatly enhancing the value of your Delta Homecraft Tools.

Widely interchangeable, most of them can be used on several models of the same tool, and many can be used on other tools. They're extremely easy to install—and they are surprisingly low in price.

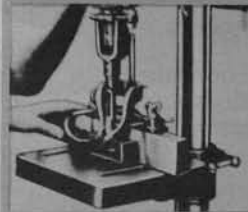

Drill square holes. This mortising operation is needed for door and screen construction and repair.



In addition to wood—light metal can also be turned on the Delta Homecraft Lathe.

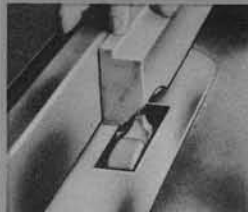

Cut decorative moldings on your circular saw with the moulding cutterhead attachment... make picture frames, base boards, table edges.

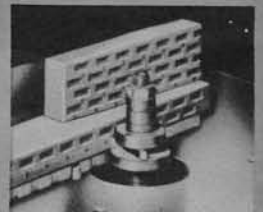

Cut moulded shapes, beads, flutes, etc. — a wide variety of shaper cutters are available for your selection.



Your Delta Homecraft Drill Press will do shaping, too—just attach the proper cutterhead and shaping attachment to make beautiful moldings.



If rust accumulates on your tools or household equipment, attach a wire or fibre brush to your Homecraft Sander and your problem is solved.

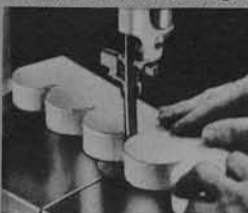

Belt sanding on the Homecraft Band Saw puts a wonderful finish on any exterior curved surface—is the best way to sand difficult-to-reach parts.

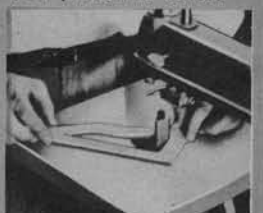

For irregular curves, you can't find a better finishing method than the Homecraft Scroll Saw with a sanding drum attachment.

CIRCULAR SAW AND JOINTER ACCESSORIES

FOR 34-500 8" TILTING ARBOR SAW ONLY

A TABLE EXTENSIONS

2 to set, each 22" x 5". Wt., 22 lbs.
Cat. No. 34-964.....\$15.95

BELT GUARD

Wt., 8 lbs. Cat. No. 34-965.....\$ 5.70

B SPLITTER MOUNTED GUARD

With anti-kickback fingers. Wt., 10 lbs.
Cat. No. 34-966.....\$6.25

SUPER-SAFE BLADE GUARD AND SPLITTER

With Anti-kickback fingers. Wt., 12 lbs.
Cat. No. 34-967.....\$12.75

CIRCULAR SAW TABLE INSERT

(Note: This is included with basic machine.)
Wt., 2 lbs. Cat. No. 34-961.....\$ 1.50

MOULDING CUTTERHEAD TABLE INSERT

Cat. No. 34-962.....\$ 1.50

DADO HEAD TABLE INSERT

Cat. No. 34-963.....\$ 1.50

C AUTO-SET MITER GAUGE

(Note: This is included with basic machine.)
Swings 60° either way. Individually adjustable
index stops. Heavy 3/8" x 3/4" bar, 17" long—full
5/8" dia. stop rods with two clamps. Wt., 4 lbs.
Cat. No. 864.....\$6.50

D CLAMP ATTACHMENT FOR MITER GAUGE

Allows you to clamp work tightly and securely.
Screws onto the miter gauge. Easily installed,
removed. Wt., 2 1/4 lbs. Cat. No. 865.....\$3.45

EXTRA CLAMP SCREWS and block for clamp
attachment. Wt., 1 lbs. Cat. No. 873.....\$.65

E TENONER

Work is fed to saw with one hand, far removed
from revolving blade. Takes stock up to 2 3/4"
thick, any width within the capacity of saw, and
will cut tenons to full capacity. Complete with
base plate. Wt., 31 lbs. Cat. No. 1172 \$32.95

BLADE SPACING COLLAR SET for tenoner. One
1/4" and one 3/8" collar. Wt., 1 lbs.
Cat. No. 1171.....\$2.25

RUBBER FEET. For steel stand. (Note: Cannot be
used with retractable caster set.)
Cat. No. 50-353.....\$1.00

FOR 34-110 8" TILTING TABLE SAW ONLY

MITER GAGE. (Note: Included with basic machine.)
For accuracy in angle cutting. Pivots 60° right and
left. Wt. 4 lbs.
Cat. No. 34-903.....\$2.00

RUBBER FEET. For steel stand. (Note: Cannot be
used with retractable caster set.)
Cat. No. 50-353.....\$1.00

BLADE GUARD. With splitter and anti-kickback
fingers. (Note: Included with machine.) Wt. 2 lbs.
Cat. No. 34-900.....\$2.60

CIRCULAR SAW TABLE INSERT. (Note: Included
with machine.) Wt. 1 lb.
Cat. No. 34-904.....\$.55

MOULDING CUTTER INSERT.
Cat. No. 34-906.....\$.55

DADO HEAD INSERT.
Cat. No. 34-905.....\$.55

FOR ALL DELTA HOMECRAFT CIRCULAR SAWS

USE THE RIGHT SAW BLADE FOR BEST RESULTS

These blades are made of the finest steel, with
properly shaped teeth, correctly tempered—
real production blades that will give you a lot
of service. They're made to cut exceptionally
well and clean—the same type of blades used
in factories. All are 8" diameter, have 5/8" arbor
hole.

F NOVELTY BLADE

Flat ground with 4 cutting teeth to each raker
tooth. Cat. No. 34-803.....\$2.50

G RIP BLADE

Cat. No. 334.....\$3.15

H CROSS-CUT BLADE

Cat. No. 335.....\$3.15

HOLLOW GROUND BLADE

Cat. No. 326.....\$5.25

COMBINATION RIP AND CROSS-CUT BLADE

Cat. No. 325.....\$3.15

USE DADO HEAD ACCESSORIES TO CUT ACCURATE GROOVES

The Dado Head is a circular saw attachment for
which you will find a lot of use because with it you
cut grooves varying in width from 1/8" to 1 3/8"
and up to 1 1/4" deep. The dado replaces the blade in
your circular saw. By a combination of outside blades
and center rakes, any width groove can be cut at
one pass over the table.

J DADO HEAD SET

Consists of two blades and five rakes with 6 paper
washers for minute adjustments. Made of steel. 5/8"
arbor hole. For No. 34-500 and No. 34-110
circular saws.
Cat. No. 34-334.....\$17.50

USE MOULDING CUTTERHEAD ACCESSORIES TO MAKE BEAUTIFUL MOULDINGS

HEAVY DUTY CADMIUM PLATED STEEL CUTTERHEAD

Fits 1/2" and 5/8" arbor. Cat. No. 265.....\$5.95

WRENCH

Cat. No. 1521.....\$.30

BASIC MOULDING CUTTERHEAD AND KNIFE SET

includes No. 265 cadmium plated steel cutterhead,
No. 1521 wrench, bushing which allows use of
cutterhead on most 8" and 10" saw arbors, and
No. 35-102 single set of cutter knives.
Cat. No. 34-821.....\$9.95

K MOULDING CUTTER SET

Consists of heavy duty cadmium plated steel head,
4 sets of 3 knives each, and special wrench. Knives
lock into head. Can be used on either the No.
34-500 or No. 34-110 circular saws, or on most
other saws with either 1/2" or 5/8" arbors. (Note:
Be sure to order the proper table insert for your
saw.)
Cat. No. 34-813.....\$21.20

FIFTY-THREE SETS OF KNIVES

Any conceivable moulding can be made using
the Delta moulding cutterhead knives listed below.
Each set contains 3 identical knives made
of high-speed steel. Order by catalog number.
Wt. 1/4 lb. each set.

Cat. No.	Description
35-100	1/2" Cove, 5/16" Quarter Round
35-101	5/16" Cove, 3/8" Bead
35-102	1/8" and 3/8" Quarter Round and 1/4" Bead
35-103	1/4" and 1/2" Quarter Round
35-104	Straight
35-106	90° Flute
35-110	Drawer Joint
35-120	Ogee
35-121	Sash
35-123	Cabinet Form (Male)
35-126	Cabinet Form (Female)
35-131	Glue Joint
35-190	3 Bead (3/16" Bead)
35-191	3 Flute (3/16" Flute)
35-192	3 Bead (1/4" Bead)
35-193	3 Flute (1/4" Flute)
35-194	5 Flute (1/8" Flute)
35-195	5 Bead (1/8" Bead)
35-196	Wedge Tongue
35-197	Wedge Groove
35-198	Ogee and 5/32" Quarter Round Table Edge
35-200	Clover Leaf Screen Moulding (9/32" x 9/16")
35-201	1/2" Flute
35-202	1/2" Bead
35-204	3/4" Flute
35-206	Pgee R. H.
35-208	Cove Sash
35-209	Bead Sash
35-211	1" Flute
35-212	3/8" Bead
35-213	Beaded Screen Moulding
35-221	Thumb Moulding
35-222	1/2" Cove and 1/4" Flute
35-223	Ogee
35-224	5/8" Cove
35-225	Flute Bead, Quarter Round and Ogee Comb
35-226	Flute Bead, Quarter Round and Ogee Comb
35-227	Flute Bead, Quarter Round and Ogee Comb
35-228	Flute Bead
35-229	Step Moulding
35-230	Pilaster Flute
35-233	5/16" Flute

Continued on next page

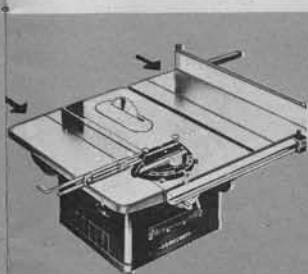

A

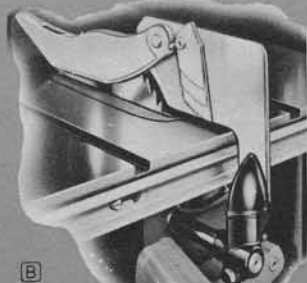

B

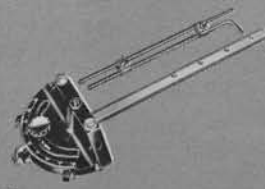

C

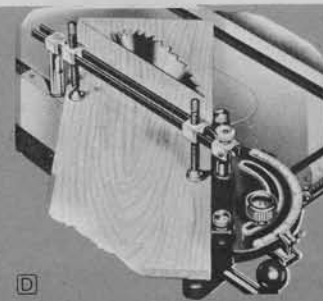

D

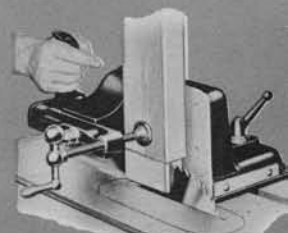

E



F



G



H



K

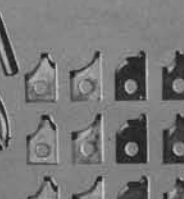

I

CIRCULAR SAW AND JOINTER ACCESSORIES CONT.

- 35-234 5/16" Bead
- 35-235 3/8" Flute
- 35-236 5/8" Flute
- 35-237 5/8" Bead
- 35-238 3/4" Bead
- 35-241 1/4" Tongue
- 35-242 1/4" Groove
- 35-243 Ogee
- 35-245 Oval Sash
- 35-246 Oval Cove

35-247 Door Lip
Price \$3.95 Each Set

FOR 37-290 AND 37-110 4" JOINTERS

JOINTER CUTTERHEAD

(Included with basic machine; can be ordered separately.) Complete with high speed steel

knives and lubricated-for-life ball bearings.
Cat. No. 37-806.....\$17.75

EXTRA SET OF KNIVES. For Nos. 37-290 and 37-110 jointers. Wt. 1/2 lb.
Cat. No. 37-802.....\$3.90

RUBBER FEET. For steel stand. (Note: Cannot be used with retractable caster set.)
Cat. No. 50-353.....\$1.00

SCROLL SAW ACCESSORIES

BASIC ACCESSORIES FOR THE SCROLL SAW

RUBBER FEET.

For No. 50-716 steel stand. (Note: Cannot be used with retractable caster set.)

Cat. No. 50-353.....\$1.00

LAMP ATTACHMENT

With shade, socket, cord, four flat links, bolts, spacer and attachment bracket. Uses 15 or 25-watt bulbs. Cat. No. 882.....\$3.40

A) BLADE GUIDES

Tempered steel. Each has blade opening of different width to accommodate various size blades. Use instead standard guide for longer blade life, straighter cuts. Set of 6. Cat. No. 40-805..\$1.45

B) SELF-CENTERING LOWER JAW CHUCK

Special jaw for upper chuck. Valuable aid in fine marquetry and puzzle work. Holds thin blades securely in center of chuck. Cat. No. 715..\$1.50

CONVERT YOUR SCROLL SAW TO A 4-SPEED MACHINE

This motor and arbor pulley set will give you your ready-to-use speeds, 650, 1000, 1300, and 1725 rpm.

MOTOR PULLEY, 1/2" bore

Cat. No. 718.....\$1.45

ARBOR PULLEY, 3/8" bore

Cat. No. 720.....\$1.85

USE THE RIGHT SAW BLADE FOR BEST RESULTS

The scroll saw blades listed are made of the finest alloy steel—especially hardened and tempered, precision-filed to razor sharpness and set—gives faster, easier, more accurate cutting. All are 5" long, have 5/8" blank ends for fastening into chuck. 6 to package. 1/8 lb.

Cat. No.	Material Cut	Thick In.	Wdth In.	List Price	Blade Full Size
58	Steel • Iron Lead • Copper Aluminum	.020	.070	.40	
59	Pewter • Asbestos Paper • Felt	.020	.070	.40	

Cat. No.	Material Cut	Thick In.	Wdth In.	List Price	Blade Full Size
60	Steel • Iron • Lead Copper • Brass	.020	.070	.40	
61	Aluminum Pewter • Asbestos Wood	.020	.085	.40	
64	Asbestos • Brake Lining • Mica	.020	.110	.40	
65	Steel • Iron • Lead Copper • Brass Aluminum Pewter	.028	.250	.55	
77	Wood Panels and Veneers	.010	.048	.30	
81	Plastics • Celluloid Hard Rubber	.010	.070	.30	
82	Bakelite • Ivory Wood	.010	.055	.30	
83	Wood Veneer Plus Plastics • Celluloid Hard Rubber Bakelite • Ivory Extremely Thin Materials	.010	.045	.30	
84	Plastics • Celluloid Hard Rubber Bakelite • Ivory Extremely Thin Materials	.008	.035	.30	
85	Plastics • Celluloid Hard Rubber Bakelite • Ivory Wood	.019	.050	.30	
86	Plastics • Celluloid Hard Rubber Bakelite • Ivory Wood	.019	.055	.30	
87	Bakelite • Ivory Wood	.020	.070	.30	
88	Bakelite • Ivory Wood	.020	.110	.30	
91	Wall Board Pressed Wood Wood • Lead Bone • Felt • Paper Copper • Ivory Aluminum	.020	.110	.40	
92	Hard and Soft Wood	.020	.110	.30	
93	Hard and Soft Wood	.028	.187	.40	
94	Hard and Soft Wood	.028	.250	.50	
95	Pearl • Pewter Mica	.016	.054	.40	
96	Pressed Wood Sea Shells	.016	.054	.40	
97	Jewelry • Metals Hard Leather	.020	.070	.30	
98	Jewelry • Metals Hard Leather	.020	.085	.40	

SABER BLADES

Made of best steel, accurately hardened and set.
5" long overall. 6 to a package. Wt. 3/8 lb.

Cat. No. 703—1/2 doz. .025" thick, .187" wide,
9 teeth per inch.....\$.45
Cat. No. 704—1/2 doz. .035" thick, .250" wide,
7 teeth per inch.....\$.50

DO SANDING AND FILING ON YOUR SCROLL SAW

Built to sand concave, convex or flat surfaces, this attachment saves many hours of hand labor. Knurled knob expands the body of attachment and tightens garnet sleeve securely. 1 5/16" wide, 1/2" thick and 2 1/2" long. 1/4" diameter shank fits lower jaw of scroll saw.

C) SANDING ATTACHMENT

With 1 sleeve. Cat. No. 711.....\$2.00

SLEEVES

No. 1 grit medium garnet. Package of 6.

Cat. No. 841.....\$1.00

SLEEVES

No. 1/0 grit fine garnet. Package of 6.

Cat. No. 842.....\$1.00

MACHINE FILES

Machine files specifically designed for fast, accurate filing of cutting teeth on saw blades, metal shapes, etc.

Machine Files with 1/4" shank.

Cat. No. 726 Square.....\$1.15

Cat. No. 727 Crochet.....1.15

Cat. No. 728 Half Round.....1.15

Cat. No. 729 Round.....1.15

Cat. No. 730 Triangle.....1.15

Cat. No. 731 Oblong.....1.15

Cat. No. 740 Complete set of 6 files.... 6.60

Machine Files with 1/8" shank.

Cat. No. 751 Square.....\$1.15

Cat. No. 752 Crochet.....1.15

Cat. No. 753 Half Round.....1.15

Cat. No. 754 Round.....1.15

Cat. No. 755 Triangle.....1.15

Cat. No. 756 Oblong.....1.15

Cat. No. 757 Lozenge.....1.15

Cat. No. 758 Knife.....1.15

Cat. No. 760 Complete set of 8 files.... 8.75



DRILL PRESS ACCESSORIES

FOR THE BASIC MACHINE

V-BELT

(Included with machine.) 3/6" out. cir. Wt., 1/2 lb. Cat. No. 340.....\$1.15

4-STEP MOTOR PULLEY

(Included with machine.) 1/2" bore. With set screws. Wt., 2 1/2 lbs. Cat. No. 985.....\$2.30

A LAMP ATTACHMENT

With shade, socket and cord, flat links, bolts and attachment bracket. Wt., 1 1/2 lbs. Cat. No. 882.....\$3.40

B SPINDLE

With Geared Chuck and Key—1/2" Cap. Wt., 3-1/2 lbs. Cat. No. 972.....\$13.75

C SPINDLE

With 1/2" hole. For routing, mortising, shaping and sanding. Wt., 2 1/2 lbs. Cat. No. 974.....\$3.40

RUBBER FEET. For steel stand. (Note: Cannot be used with retractable caster set.) Cat. No. 50-353.....\$1.00

FOR DRILLING AND SIMILAR OPERATIONS

(These cutting tools are used on the No. 972 spindle furnished with your Delta Homecraft Drill Press.)

D AUGER BITS—The wide variety of sizes will help you do a good job on your workshop projects.

Cat. No.	Description	
11-811	1/4" Auger Bit	\$.65
11-812	5/16" Auger Bit	1.00
11-813	3/8" Auger Bit	1.25
11-814	7/16" Auger Bit	1.60
11-815	1/2" Auger Bit	1.95
11-817	5/8" Auger Bit	2.40
11-818	3/4" Auger Bit	3.10
11-821	Complete Set of Auger Bits	11.50

MACHINE SPUR BITS—Made of selected tool steel. Have brad point and two cutting lips. Approximately 6-1 1/4" long overall with 1/2" shank.

Cat. No.	Description	
804	1/4" Machine Spur Bit	\$ 1.70
805	5/16" Machine Spur Bit	1.70
806	3/8" Machine Spur Bit	1.90
807	7/16" Machine Spur Bit	2.20
808	1/2" Machine Spur Bit	2.45
809	9/16" Machine Spur Bit	2.75
810	5/8" Machine Spur Bit	3.20
812	3/4" Machine Spur Bit	4.00
818	Complete Set of Machine Spur Bits	19.25

F PLUG CUTTERS—Used for making plugs and dowels. 1/2" x 3" shank, barrel 2-1/4" long.

Cat. No.	Description	
814	3/8" Plug Cutter	\$ 4.75
815	1/2" Plug Cutter	4.75

816	5/8" Plug Cutter	5.50
817	3/4" Plug Cutter	6.10
819	1" Plug Cutter	7.50
822	Complete Set of Plug Cutters	27.50

G ROUTER BITS—Used for making round-end mortises and grooving work, 1/2" x 1-1/2" shank. Use with No. 974 spindles.

Cat. No.	Description	
474	1/4" Router Bit	\$ 1.70
475	5/16" Router Bit	1.70
476	3/8" Router Bit	1.70
477	7/16" Router Bit	1.70
478	1/2" Router Bit	1.70
480	Complete Set of Router Bits	8.25

FOR SURFACE GRINDING, TOOL GRINDING, AND POLISHING

K SPINDLE

For cup grinding wheels. Wt., 2 lbs. Cat. No. 991.....\$3.40

L CUP WHEEL

Extremely useful for grinding and surfacing on the drill press. Furnished 3 1/2" dia., 1 1/2" wide with 1/2" arbor hole to fit No. 991 spindle. No. 60 grit. Wt., 1 lb. Cat. No. 992.....\$3.85

FOR YOUR SANDING OPERATIONS

AUXILIARY SHAFT

1/2" x 2 1/2". Cat. No. 11-834.....\$.70

SANDING DRUMS:

H 3" dia. x 3", with one sleeve. (Fits No. 974 spindle when used with No. 11-834 auxiliary shaft.) Cat. No. 830.....\$4.75

1 3/4" dia. x 2", with one sleeve. (Fits No. 974 spindle when used with No. 11-834 auxiliary shaft.) Cat. No. 835.....\$3.10

U 1 1/8" dia. x 2 1/2", with one sleeve. (Has 1/2" shank to fit hollow spindle or chuck; fits No. 974 spindle.) Cat. No. 840.....\$1.65

1 1/2" dia. x 1", 3/16" shank; with one sleeve. (Fits No. 972 spindle.) Cat. No. 679.....\$1.50

2 3/8" dia. x 1", 3/16" shank; with one sleeve. (Fits No. 972 spindle.) Cat. No. 680.....\$1.65

3" dia. x 1", 3/16" shank; with one sleeve. (Fits No. 972 spindle.) Cat. No. 681.....\$1.85

SLEEVES FOR SANDING DRUMS:

For 3" dia. x 3" drum. No. 1 1/2 grit, coarse garnet. 1/2 doz. Wt., 1/2 lb. Cat. No. 831.....\$1.25

For 3" dia. x 3" drum. No. 1/2-60 grit medium garnet. 1/2 doz. Wt., 1/2 lb. Cat. No. 832..\$1.25

For 3" dia. x 3" drum. No. 1-50 grit Al. Oxide (for metal). 1/2 doz. Wt., 1/2 lb. Cat. No. 833.....\$1.85

For 1 3/4" dia. x 2" drum. No. 1 1/2-40 grit medium garnet. 1/2 doz. Wt., 1/4 lb. Cat. No. 836.....\$1.00

For 1 3/4" dia. x 2" drum. No. 1/2-60 grit fine garnet. 1/2 doz. Wt., 1/4 lb. Cat. No. 837..\$1.00

For 1 3/4" dia. x 2" drum. No. 1-50 grit Al. Oxide (for metal). Wt., 1/4 lb. Cat. No. 838.....\$1.15

For 1 1/8" dia. x 2 1/2" drum. No. 1 grit medium garnet. Wt., 1/2 lb. Cat. No. 841.....\$1.00

For 1 1/8" dia. x 2 1/2" drum. No. 1/0-80 grit fine garnet. 1/2 doz. Wt., 1/2 lb. Cat. No. 842..\$1.00

For 1 1/8" dia. x 2 1/2" drum. No. 50 grit Al. Oxide (for metal). 1/2 doz. Wt., 1/2 lb. Cat. No. 847.....\$1.15

For 1 1/2" dia. x 1" drum. No. 40 grit Al. Oxide. 1/2 doz. Wt., 1/4 lb. Cat. No. 682.....\$.85

For 1 1/2" dia. x 1" drum. No. 80 grit Al. Oxide. 1/2 doz. Wt., 1/4 lb. Cat. No. 683.....\$.85

For 2 3/8" dia. x 1" drum. No. 40 grit Al. Oxide. 1/2 doz. Wt., 1/4 lb. Cat. No. 684.....\$.85

For 2 3/8" dia. x 1" drum. No. 80 grit Al. Oxide. 1/2 doz. Wt., 1/4 lb. Cat. No. 685.....\$.85

For 3" dia. x 1" drum. No. 40 grit Al. Oxide. 1/2 doz. Wt., 1/2 lb. Cat. No. 686.....\$1.00

For 3" dia. x 1" drum. No. 80 grit Al. Oxide. 1/2 doz. Wt., 1/2 lb. Cat. No. 687.....\$1.00

FOR MORTISING (Cutting square holes)

With the addition of the No. 976 Mortising Attachment and the No. 974 Spindle, the Homecraft Drill Press may be converted into an accurate mortising machine. 3/4" thick capacity under hold down. Capacity from ends of hooked rods to fence, 2 3/4" thick.

M MORTISING ATTACHMENT COMPLETE

With heavy fence, hold-down bracket, hold-down and rod, curved arms, bolts, chisel holder, and 3/16", 3/8" and 1/2" hole bushings. Without spindle. Wt. 7 1/2 lbs. Cat. No. 976.....\$9.75

CHISELS:

N 1/4". Cat. No. 634.....	\$4.00
3/8". Cat. No. 636.....	4.25
1/2". Cat. No. 638.....	4.50

BITS:

O 1/4". Cat. No. 514.....	\$2.10
3/8". Cat. No. 516.....	2.10
1/2". Cat. No. 518.....	2.10

BUSHINGS:

(Note: Included with No. 976 Mortising Attachment.)
P 3/16". For 3/8" and 1/2" bits. Cat. No. 524.....\$.60
 1/4". For 3/8" and 1/2" bits. Cat. No. 526......60

USE THIS SHAPING ATTACHMENT TO MAKE BEAUTIFUL MOULDINGS

These three-lip cutters provide hundreds of moulding shapes. In addition, a blank cutter is provided for grinding your own shapes.

R SET OF 24 SHAPER CUTTERS

With 978 adapter and 6 collars in a box. (Note: Each cutter as well as collars and adapter can

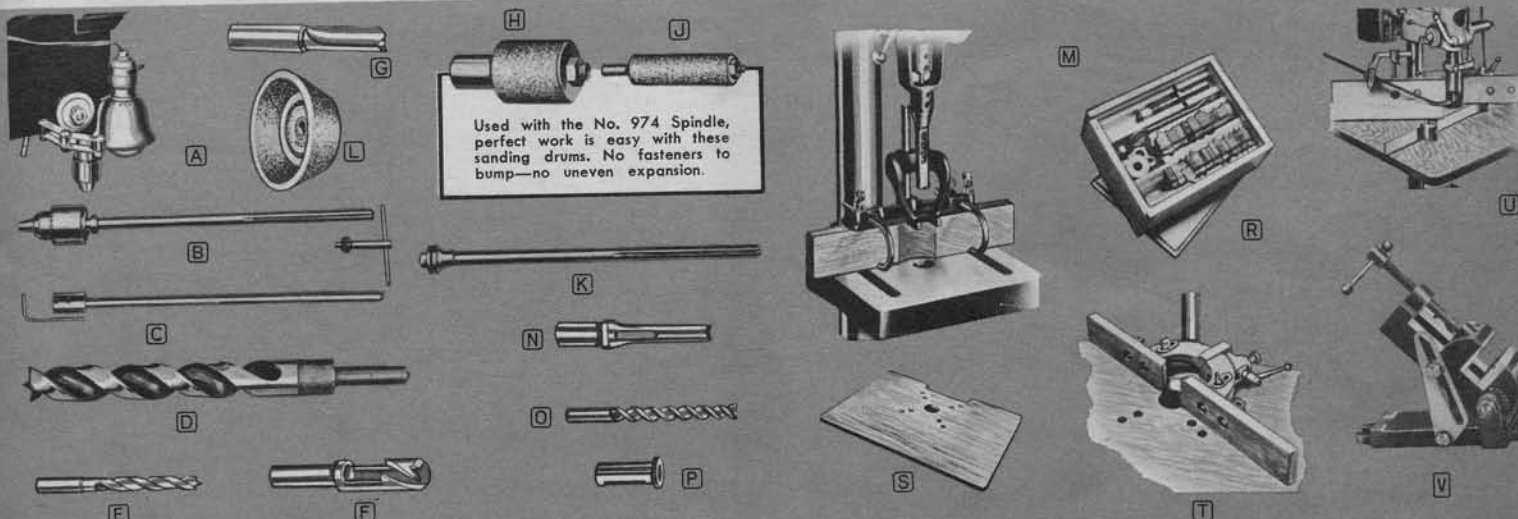

DRILL PRESS ACCESSORIES CONT.

be ordered separately.) Wt., 2 lbs.
Cat. No. 980\$34.50

Set of above shaper cutters can also be used on No. 43-110 Shaper.

S PLYWOOD SHAPER TABLE
 Made of plywood and drilled for easy fastening to top of regular drill press table. 17¹³/₁₆" x 23¹³/₁₆", 3/4" thick.
Cat. No. 11-806\$11.50

T SHAPER FENCE

Fully adjustable; both halves independent of each other. Adjustable endwise. Wt., 12 lbs.
Cat. No. 982\$12.95

U SPRING HOLD DOWNS
 Holds work against fence and table. Can be used on either end of the fence. Wt., 2 lbs.
Cat. No. 983\$4.50

SPINDLE
 For shaper cutters with 3/16" holes. Wt., 2 lbs.
Cat. No. 977\$3.40

V VISES—Of tested quality and usefulness these vises are excellent for drill press work. Accurately machined with base, body and sliding jaws of semi-steel, clamping jaws of hardened steel.

Cat. No.	Jaw	Opening	Length	Price
1024*	1-1/2x1	1-5/8	4-5/8	\$ 5.60
1025	1-1/2x1	1-5/8	4-5/8	7.35
1026	2-1/2x1-7/16	2-1/2	6-1/4	11.50

*No. 1024 same as No. 1025 but without angle raising feature.

LATHE ACCESSORIES

BASIC LATHE ACCESSORIES

Chisels for Metal and Plastic Turning:

- Tungsten-tipped
- 1/8" Square Nose. **Catalog No. 46-801** \$ 5.25
- 1/8" Round Nose. **Catalog No. 46-802** 5.25
- 1/4" Square Nose. **Catalog No. 46-803** 5.25
- 1/4" Round Nose. **Catalog No. 46-804** 5.25

Screw Center. **Catalog No. 940** 2.85

6" Face Plate (right and left hand combination thread). **Catalog No. 937**\$ 3.40

CAST IRON BENCH LEGS

(Included with bench—buy only when you make bench.) No bench twist—strong, solid with all holes 3/8". **Cat. No. 945**. One pair.....\$22.50

A 24" TOOL SUPPORT

For extra long turnings. Two 1" dia. shanks. Requires extra 941A base.
Cat. No. 694\$4.00

B RIGHT-ANGLE TOOL SUPPORT

1" dia. shank. For face plate work.
Cat. No. 695\$2.25

C HEAVY, RIGID FLOOR STAND

For face plate work on the left of spindle. Tripod legs, pipe support V-hole for 1/2" to 1" shank. Knocked down. **Cat. No. 697**\$17.25

D BENCH

Wood top and shelf. Cast iron legs. Wt., 95 lbs.
Catalog No. 46-845\$45.00

E BALL BEARING CENTER

(Replaces No. 934 for metal spinning, etc.) Double row, sealed-for-life ball bearings. With three replaceable centers and wrench. No. 2 Morse taper. **Cat. No. 1490**\$12.00

GEARED CHUCK

For horizontal drilling. 1/2" capacity.
Cat. No. 968\$10.75

HAND WHEEL

For quick stopping or positioning of lathe work. 1"-8 thread; 5" diameter.

Catalog No. 938\$ 2.50

STEADY REST

For turning long thin stock on your lathe. Capacity 2 1/4".

Catalog No. 948-A\$ 6.50

DO METALWORKING ON YOUR LATHE

F COMPOUND SLIDE REST

Accurately built, with dovetail slides and graduated compound base which rotates 360 degrees. Feed screws are fitted with micrometer sleeves for fine adjustments. **Cat. No. 46-965**\$43.50

HOLDER, BORING BARS AND TOOL BITS FOR USE WITH THE SLIDE REST

Holder for boring bars and tool bits.
Cat. No. 46-963\$3.75

G Set of three boring bars, 1/8", 3/16" and 1/4".
Cat. No. 46-966\$2.30

H Set of 4 high speed tool bits 1/4" x 1/4" x 7/8", roughing, finishing, right corner and left corner.
Cat. No. 46-954\$2.00

COUNTER SHAFT UNIT

Consisting of (2) No. 49-370 hangers, No. 378 shaft, No. 718 pulley (specify bore for motor), No. 720 pulley (3/4" bore for shaft), No. 932 pulley (3/4" bore), No. 284 V-belt, (2) No. 49-374 collars, bolts and nuts. **Cat. No. 1464** ...\$18.00

DO DISC SANDING ON YOUR LATHE

J SANDING TABLE

Raises, lowers, tilts; graduated for accurate work.
Cat. No. 46-948\$14.75

K MITER GAUGE FOR SANDING TABLE

Provides accurate angles. Wt., 4 lbs.
Cat. No. 34-903\$2.00

SANDING DISC FOR 11" LATHE

8 1/2". Wt., 2 1/4 lbs. **Cat. No. 46-934**\$3.75

COARSE GARNET PAPER DISK

No. 40 grit, 8 3/8" dia. Packages of 12.
Cat. No. 46-815\$2.30

FINE GARNET PAPER DISK

No. 80 grit, 8 3/8" dia. Package of 12.
Cat. No. 46-817\$1.70

DISK ADHESIVE

Wt., 1 lb. **Cat. No. 49-503**\$.85

DO DRUM SANDING ON YOUR LATHE

M 3" x 3" SANDING DRUM

Cat. No. 163\$5.75

1 3/4" x 2" SANDING DRUM

Cat. No. 164\$3.50

For sanding sleeves see drill press accessories, Page 19.

DO BUFFING, GRINDING, POLISHING

L LEFT HAND SCREW-ON ARBOR

Cat. No. 145\$3.00

RIGHT HAND SCREW-ON ARBOR

Cat. No. 144\$3.00

For buffing, grinding, wire and fibre wheels, see abrasive accessories, Page 22.

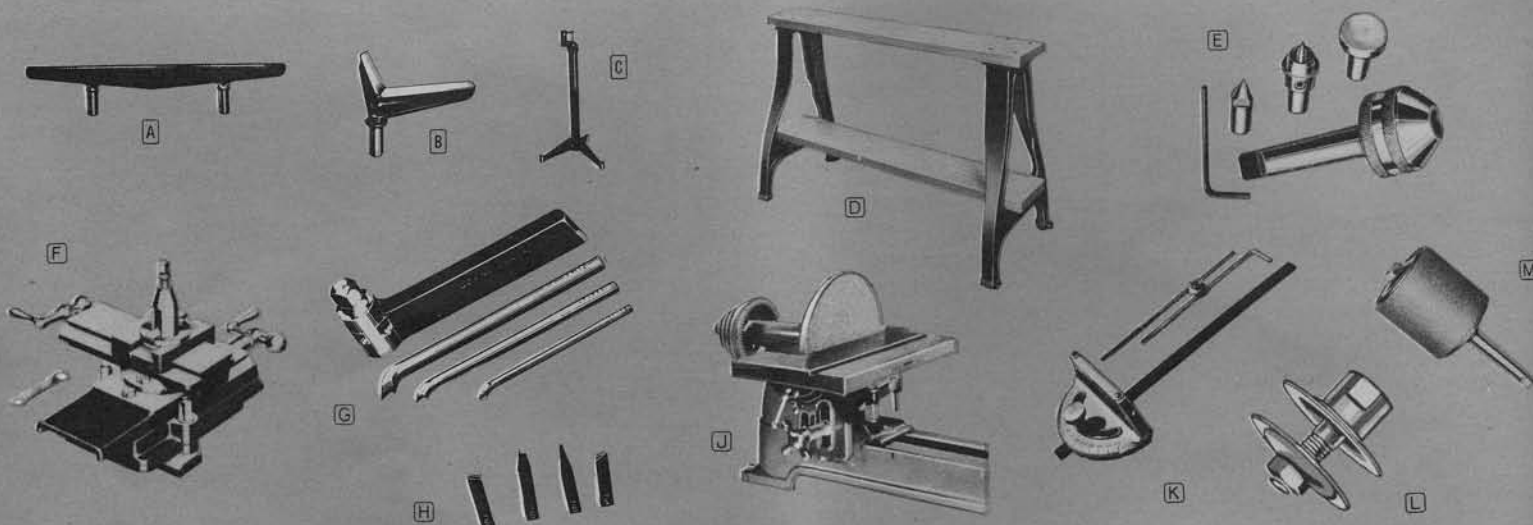

SHAPER ACCESSORIES

BASIC ACCESSORIES FOR THE SHAPER

RUBBER FEET. For steel stand. Wt. 1 lb.
Cat. No. 50-353 \$1.00

SHAPER FENCE

Complete with wood facings, bolts and wing nuts. (Incl. with basic machine; can be ordered separately.) Wt., 12 lbs. Cat. No. 982.....\$12.95

AUTO-SET MITER GAUGE

Wt., 4 lbs. Cat. No. 864.....\$6.50

SAFETY RING GUARD

Protects user on curved and circular work. Fully adjustable and easily removed. Wt., 8 lbs.
Cat. No. 43-817.....\$6.85

STUB SPINDLE

With screw and Allen wrench for counterbored 3-Lip Cutters. Cat. No. 1190.....\$3.40

Set of Table Inserts with Guide Shoulders SR-253, 2 3/8" dia. and SR-254, 1 3/8" dia. Wt., 1/2 lb. Cat. No. 1198.....\$1.10

3-LIP CUTTERS AND COLLARS

Offer unlimited possibilities in making hundreds of moulding shapes. One-piece, they have involute relief, and honing the face does not change the shape. The collars for use with the cutters are ground to size.

3-LIP CUTTERS

D-100	1/2" Cove, 5/16" Quarter Round	\$2.35
D-101	5/16" Cove, 3/8" Bead	2.35
D-102	1/8" and 3/8" Quarter Round, 1/4" Bead	2.35
D-103	1/4" and 1/2" Quarter Round	2.35
D-106	90° Flute	2.35
D-109	1/4" Flute	1.50
D-110	Drawer Joint	2.35
D-120	Ogee	2.00
D-121	Female Sash	2.00
D-123	Cab. R. H. Male	2.00
D-124	Cab. L. H. Male	2.00
D-125	Cab. R. H. Female	2.00
D-126	Cab. L. H. Female	2.00
D-128	Male Sash	2.00
D-131	Glue Joint	2.75
D-135	Cove and Bead Moulding L. H.	2.00
D-136	Cove and Bead Moulding R. H.	2.00
D-137	Cove and Bead Cope R. H.	2.00
D-138	Cove and Bead Cope L. H.	2.00
D-190	3-Bead (3/16")	2.00
D-191	3-Flute (3/16" Flute)	2.00
D-192	3-Bead (1/4" Bead)	2.35
D-193	3-Flute (1/4" Flute)	2.35
D-194	5-Flute (1/8" Flute)	2.35
D-195	5-Bead (1/8" Bead)	2.35
D-196	Wedge Tongue	2.75
D-197	Wedge Groove	2.75
D-198	Ogee and Bead Table Edge	2.75

D-199	1" Convex Edge	2.75
D-200	Clover Leaf Screen Mldg. (9/32" x 9/16")	2.75
D-201	1/2" Flute	2.00
D-202	1/2" Bead	2.00
D-203	1/4" Bead	2.00
D-204	3/4" Flute	2.00
D-205	Pgee R. H.	2.00
D-206	Pgee L. H.	2.00
D-207	Cove Sash L. H.	2.00
D-208	Cove Sash R. H.	2.00
D-209	Bead Sash L. H.	2.00
D-210	Bead Sash R. H.	2.00
D-211	1" Flute	2.35
D-212	3/8" Bead	2.00
D-213	Beaded Screen Moulding	2.00
D-214	Panel Raising	2.75
D-219	1" Bead	2.75
D-228	Flute-Bead	2.35
D-229	Step Moulding	2.35
D-230	Pilaster Flute	2.35
D-231	9/16" Quarter Round	2.35
D-235	3/8" Flute	2.00
D-238	3/4" Bead	2.75
D-247	Door Lip	2.75
D-250	3/8" & 3/16" Radii R. H.	2.35
D-251	3/16" & 3/8" Radii L. H.	2.35
D-252	1/4" & 1/2" Radii L. H.	2.35
D-253	1/2" & 1/4" Radii R. H.	2.35
D-254	5/16" & 1/8" Radii Cutter R. H.	2.35
D-255	1/8" & 5/16" Radii Cutter L. H.	2.35

STANDARD CUTTER SETS

(These sets are made up of groups of individual cutters shown at bottom of page.)

STANDARD CUTTER SET

Consists of cutters D-100 to D-109 inclusive and collars D-142 to D-149 inclusive. Packed in wood box. Wt., 3 1/2 lbs. Cat. No. 1182.....\$26.75

COVE AND BEAD CUTTER SET

Consists of D-129, D-135 to D-139 cutters inclusive; D-132 and D-134 collars. Packed with No. 1190 Stub Spindle Assembly and Wrench in wood box. Wt., 2 lbs. Cat. No. 1178.....\$16.75

SASH AND CABINET CUTTER SET

Consists of D-108, D-120, D-121, D-123 to D-128 inclusive and D-130 cutters. D-140, D-141, D-150 and D-151 collars. Packed with No. 1190 Stub Spindle Assembly and Wrench in wood box. Wt., 3 lbs. Cat. No. 1184.....\$26.50

PGEE DOOR ASSEMBLY SET

Includes D-205, D-206 male cutters and D-217 collar. Cat. No. D-205-S.....\$4.45

PGEE DOOR ASSEMBLY SET

Includes D-205, D-206 female cutters, D-108 and D-133 collars. Cat. No. D-206-S.....\$5.50

COVE CUTTER ASSEMBLY

Includes D-207, D-208 cutters, D-133 and D-215 collars. Cat. No. D-208-S.....\$4.45

BEAD SASH CUTTER ASSEMBLY

Includes D-209, D-210 and D-108 cutters. Cat. No. D-210-S.....\$5.50

STRAIGHT CUTTERS—1/2" HOLE

D-104	1" x 1 7/8" Diameter	\$2.35
D-105	1 1/2" x 1 7/8" Diameter	2.75
D-107	1/2" x 1 7/8" Diameter	1.50
D-108	1/4" x 1 13/16" Diameter	1.50
D-137	3/8" x 1 13/16" Diameter	2.00
D-129	3/8" x 2 7/32" Diameter	2.00
D-130	3/4" x 1 7/8" Diameter	2.00
D-139	1/4" x 2 7/32" Diameter	2.00
D-218	3/8" x 2" Diameter	2.00
D-248	5/16" x 1-15/16" Diameter	2.00
D-249	5/16" x 2-7/32" Diameter	2.00
D-256	1/4" x 1-1/4" Diameter	1.50
D-257	3/8" x 1-1/4" Diameter	1.50
D-258	1/2" x 1-1/4" Diameter	1.50
D-259	5/16" x 1-1/4" Diameter	1.50

For 5/16" hole 3-lip shaper cutters see Drill Press accessories, page 19.

SHAPER COLLAR SETS

Set of 7 collars from 3/4" to 1 1/8" diameter, D-142, D-143, D-144, D-145, D-171, D-172, D-173. Wt., 3/4 lb. Cat. No. 1210.....\$3.20

Set of 6 collars from 1 3/16" to 1 1/2" diameter, D-141, D-146, D-147, D-148, D-174 and D-175. Wt., 1 lb. Cat. No. 1211.....\$3.10

Set of 6 collars from 1 1/16" to 1 7/8" diameter, D-149, D-176, D-177, D-178, D-179 and D-180. Wt., 1 1/2 lbs. Cat. No. 1212.....\$3.60

Set of 4 collars for sash cutters, D-140, D-141, D-150 and D-151. Wt., 1/2 lb. Cat. No. 1191.....\$2.10

SPACING COLLARS FOR SHAPER CUTTERS

No.	Thick	Out. Dia.	Hole	Price
D-132	3/8"	1 1/2"	1/2"	\$.45
D-133	1/2"	1 3/16"	1/2"	.45
D-134	1/4"	1 5/16"	1/2"	.45
D-140	1/4"	1 3/16"	1/2"	.45
D-141	3/8"	1 3/16"	1/2"	.45
D-142	3/8"	3/4"	1/2"	.45
D-143	3/8"	7/8"	1/2"	.45
D-144	3/8"	1"	1/2"	.45
D-145	3/8"	1 1/8"	1/2"	.45
D-146	3/8"	1 1/4"	1/2"	.45
D-147	3/8"	1 3/8"	1/2"	.55
D-148	3/8"	1 1/2"	1/2"	.55
D-149	3/8"	1 3/4"	1/2"	.70
D-150	3/16"	1 3/8"	1/2"	.50
D-151	1/4"	1 7/8"	1/2"	.70
D-155	1/4"	3/4"	1/2"	.40
D-171	3/8"	1 3/16"	1/2"	.45
D-172	3/8"	1 3/16"	1/2"	.45

Continued on next page

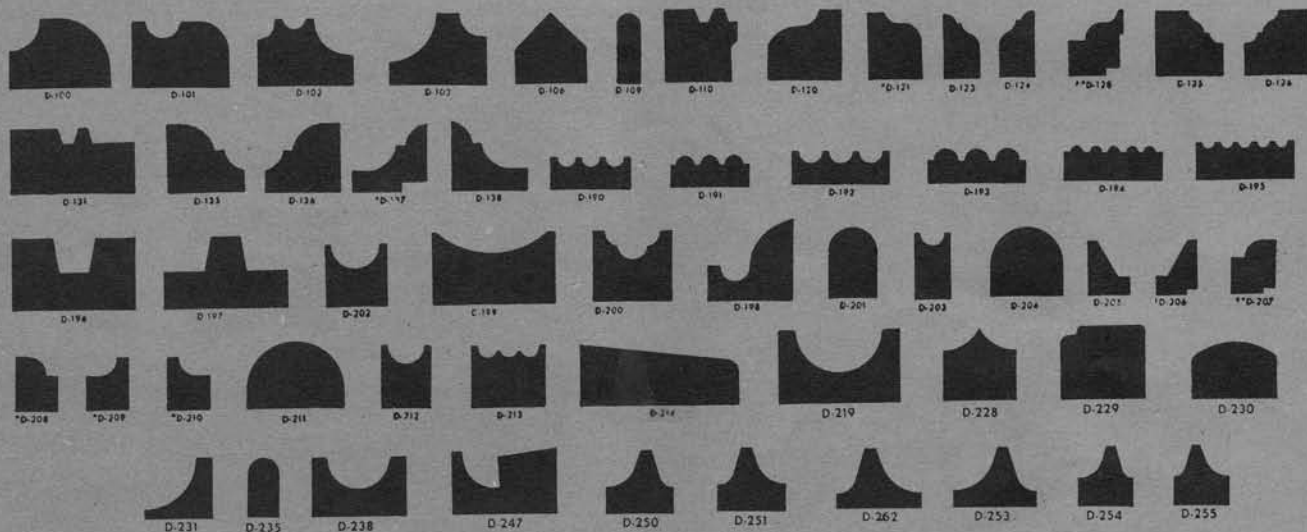

Three lip cutter (Available with profiles as shown)

SHAPER ACCESSORIES CONT.

D-173	3/8"	1 1/16"	1/2"	.45
D-174	3/8"	1 3/16"	1/2"	.50
D-175	3/8"	1 7/16"	1/2"	.50
D-176	3/8"	1 1/16"	1/2"	.50
D-177	3/8"	1 3/8"	1/2"	.55
D-178	3/8"	1 11/16"	1/2"	.70
D-179	3/8"	1 13/16"	1/2"	.55
D-180	3/8"	1 7/8"	1/2"	.70
D-215	1/4"	1 1/32"	1/2"	.45
D-217	1/4"	1 3/32"	1/2"	.45

SPECIAL SHAPER ACCESSORIES

B 3-KNIFE SAFETY CUTTER HEAD

Alloy Steel. Fits either 1/2" or 3/4" spindles. Allows you to use your Circular Saw moulding cutter knives on the Shaper. (See Circular Saw Accessories.) Without knives. Wt., 1 1/2 lbs.
Cat. No. 1343.....\$6.75

C SLIDING SHAPER JIG

Makes shaping of short and narrow pieces safe

and accurate. The hands never come close to the cutters, and the work cannot slip. Wt., 19 lbs.

Cat. No. 1186.....\$19.25

Tenoner for use with Jig. Wt., 21 lbs.

Cat. No. 1170.....\$16.95

D SPRING HOLD DOWNS

Holds work firmly against fence and table. Use it on either end of fence. Accommodates work up to 3 1/2" thick. Wt., 2 lbs. Cat. No. 983....\$4.50

BAND SAW ACCESSORIES

BASIC BAND SAW ACCESSORIES

RUBBER FEET. For No. 50-329 steel stand.

Cat. No. 50-353.....\$ 1.00

E LAMP ATTACHMENT

Brings light to work where needed—independent of shop lighting system. Can be swung out of way

by a touch of the finger. Uses 15 or 25 watt bulbs.
Cat. No. 882.....\$3.40

F TOP QUALITY BLADES—71 3/4" long

1/8" Blade. 7 teeth per in. Cat. No. 28-801...\$1.40

3/16" Blade. 7 teeth per in. Cat. No. 28-802... 1.40

1/4" Blade. 7 teeth per in. Cat. No. 28-803... 1.40

3/8" Blade. 6 teeth per in. Cat. No. 28-804... 1.40

DO SANDING ON YOUR BAND SAW

G SANDING ATTACHMENT

Consists of flat and curved platens with guides and mounting bracket. Cat. No. 28-810...\$3.45

5 GARNET SANDING BELTS. 1/2" wide x 70" long. Fine, No. 80 grit. Cat. No. 28-811.....\$2.25
Medium, No. 40 grit. Cat. No. 28-812... 2.25

ABRASIVE TOOL ACCESSORIES

H GRINDING WHEEL. 46 Grit. 6" dia., 1/2" wide, 1/2" hole. Cat. No. 3101.....\$2.00

GRINDING WHEEL. 60 Grit. 6" dia., 1/2" wide, 1/2" hole. Cat. No. 3102.....\$2.00

GRINDING WHEEL. 50 Grit. 6" dia., 5/8" wide, 1/2" hole. Cat. No. 23-620.....\$2.75

GRINDING WHEEL. 60 Grit. 6" dia., 5/8" wide, 1/2" hole. Cat. No. 23-621.....\$2.75

J WIRE WHEEL. Coarse. 6" dia. Cat. No. 3113.....\$2.55

WIRE WHEEL. Fine. 6" dia. Cat. No. 3114.....\$4.75

TAMPICO FIBER WHEEL. 6" dia. Cat. No. 3115.....\$4.15

K BUFFING WHEEL. 6" dia., 1/2" hole. Cat. No. 4005.....\$1.15

L BUFFING KIT of compounds and wheel. Cat. No. 4003.....\$2.00

BUFFING COMPOUNDS. Without wheel. Cat. No. 4004.....\$1.00

M GIANT POLISHING BARS. If you have a lot of polishing to do, get big one pound bars.

Cat. No. 4007—Red, for Gold, Silver, Sterling and all precious metals, each.....\$1.00

Cat. No. 4008—White, for Nickel, Chromium, Iron, Stainless Steel, Cast Brass and Aluminum, each.....\$1.00

Cat. No. 4009—Black, for removing rust, scale and tarnish. Has sharp cutting action, each \$1.00

Cat. No. 4010—Brown, for Aluminum, Brass, Copper, Pewter, Wood, Plastic, Painted Surfaces, Horn and Hard Rubber, each.....\$1.00

Accessory Kit. For cleaning and polishing. Kit includes No. 3113 coarse wire wheel, No. 3114 fine wire wheel, No. 3115 tampico fibre wheel and No. 4003 buffing kit of compounds and wheel.

Cat. No. 23-601.....\$8.25

MAKE YOUR OWN SANDING SHAPES

When you are working with irregular shapes where flat sandpaper will not do the job, use this new Sanding Kit. You can make disks or drums of most any shape.

N DELTA SANDING KIT. Contains 1 can adhesive, 1 can fine abrasive, 1 can coarse abrasive, and instruction label. Wt. 4 lbs. Cat. No. 4017...\$1.50

DELTA SHOP CONVERSION KITS

As your workshop grows you may wish to mount your Deltashop Drill Press so that it is always available under its own power. Special conversion kits are available for this purpose.

Kit No. 1. Includes motor mounting bracket, 4-speed pulley and belt. Cat. No. 49-190.....\$7.50

Kit No. 2. Bench type base with 6" x 7-3/4" ground table surface. Has machined parallel slots for mounting jigs and fixtures. Cat. No. 49-191.....\$6.80

The assembly listed below enables you to convert your No. 11-120 drill press to a No. 11-130 Deltashop Drill Press.

Assembly. Includes support bracket, idler pulley, mounting base, V-belt and assembly parts. Cat. No. 49-193.....\$16.50

Mounting Base. With assembly parts only. Cat. No. 49-192.....\$5.85

The following items are furnished as component parts of the No. 34-535 Deltashop. However, they can be purchased separately if you already have a jointer, drill press or sander to make up a one-motor shop.

DELTA SHOP STAND. Plywood top, drilled for easy mounting of your saw and jointer. Cat. No. 50-308.....\$18.45

JOINTER RAISING BLOCK. Enables you to mount your jointer on a working level with your saw. Cat. No. 37-113.....\$3.00

BELT AND PULLEY GROUP. For jointer drive. Consists of No. 49-182 motor pulley and No. 410 belt. Cat. No. 49-186.....\$2.65

SANDER BASE PLATE. Required to mount your sander on the circular saw. No. 281 V-belt included with package. Cat. No. 31-201.....\$2.60

ARBOR PULLEY. 2-1/4" dia. 5/8" bore. For sander and drill press drive. Cat. No. 49-189.....\$.85

BELT AND PULLEY GROUP. For circular saw drive. Consists of No. 5225 motor pulley and No. 49-152 belt. Cat. No. 49-185.....\$1.85

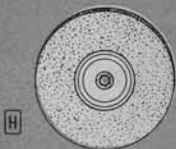
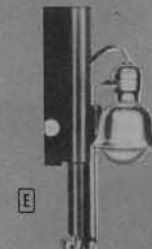
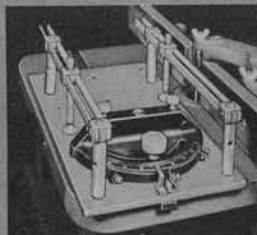

Accessories, Attachments and Materials for Every Home Workshop

GRAY MACHINE ENAMEL



Hundreds of users have purchased the attractive medium gray enamel with which we paint our machines in order to paint benches, machine stands, other tools and accessories in their shops to match. Excellent quality finish. Has a hard, smooth surface; dries quickly. May be brushed on or sprayed.

Cat. No. 49-333 1 qt. \$2.15
Cat. No. 49-334 1 gal. \$6.75

Gum and Pitch Remover

Delta gum and pitch remover keeps your tools clean, bright and new looking. It improves your cutting and makes your work cleaner and easier.

Cat. No. 4051 8 oz. \$1.60

"STOP-RUST" PREVENTS RUST FORMATION



When applied to any clean polished metal surface it eliminates the formation of most rust and oxidation. It is not sticky or oily. Apply Stop-Rust according to directions and it will give you a polished, safely-protected surface without a trace of smeariness.

No. 109—1-pint can, 1 1/4 lbs. \$.85
No. 110—Case of 12 pints, 16 lbs. 8.75

NEW, BETTER, RUST REMOVER



A non-inflammable liquid that removes rust and cuts grease and oil from iron and steel. Deltacraft Rust Remover also cleans and conditions copper, brass, aluminum, zinc die castings, galvanized iron, iron and steel.

Ready to use—apply with spray, brush, steel wool or cloth.

No. 49-320—1/2 pint bottle, 1 1/2 lbs. \$.65
No. 49-319—1 quart bottle, 4 lbs. 2.00
No. 49-321—1/2 gallon bottle, 7 lbs. 3.15
No. 49-322—1 gallon bottle, 15 lbs. 4.85

V-BELT PULLEYS



For A-section V-belts 1/2" wide, 9/16" thick and 45° angle. Safety disc type—no spokes. Perfectly balanced. Have 5/16" hollow head set screw, 5/8" and 3/4" bores have a 3/16" keyway. All sizes can be furnished in 1/8", 5/8" and 3/4" bores. 1/2" bore furnished unless

otherwise specified. Maximum bore available on Nos. 5200 to 5300 is 3/4".

Cat. No.	Out. Diam.	Price
5200	2"	\$.70
5225	2 1/4"	.70
5250	2 1/2"	.70
5275	2 3/4"	.75
5300	3"	.80
5350	3 1/2"	.80
5400	4"	.90
5450	4 1/2"	1.00
5500	5"	1.15
5550	5 1/2"	1.25
5600	6"	1.45
5650	6 1/2"	1.60
5700	7"	1.95
*5710	7 1/2"	4.25
5800	8"	2.25
6100	10"	2.80
6200	12"	3.35

*3/4" bore only.

FOUR-STEP CONE PULLEYS



Made for the same size V-belt as plain pulleys listed above. Pulleys may be used in pairs as listed in table below and will provide the speed listed in the third column when used with 1725 r.p.m. motor.

All cone pulleys available in 1/2", 5/8" and 3/4" bores; 5/8" and 3/4" bores have a 3/16" keyway. 1/2" furnished unless otherwise ordered.

718—1 1/4 lbs. \$1.45 932—2 lbs. \$2.25
720—1 1/4 lbs. 1.85 985—2 lbs. 2.30

Driver	Driven	Speeds			
718	718	900	1500	2200	3450
720	720	1200	1545	1980	2575
718	720	650	1000	1300	1725
720	718	1725	2400	3400	5000
932	932	900	1400	2200	3400
985	985	590	1275	2450	5000

V-BELTS



Designed to make perfect contact with the side of the V-groove, these A-section V-belts transmit maximum H.P. with minimum slip. Cords are saturated with pure liquid rubber, imbedded in special rubber stock to resist fatigue and carry off heat.

Note: When ordering belts for which number is not known, measure around outside diameters of pulleys, then select belt of nearest outside circumference in table.

Catalog No.	Description	Price
281	V-Belt, 28" O.C.	\$1.00
284	V-Belt, Cir. In. 28 1/2", Out. 30 3/4"	1.00
289	V-Belt, Cir. In. 44 1/2", Out. 46"	1.35
340	V-Belt, Cir. In. 34 3/4", Out. 36 1/2"	1.15
387	V-Belt, Cir. In. 37 3/4", Out. 39 3/4"	1.25
410	V-Belt, Cir. In. 39 1 3/4", Out. 42"	1.30
453	V-Belt, Cir. In. 45 3/4", Out. 47 3/4"	1.45
560	V-Belt, Cir. In. 56 3/4", Out. 58 3/4"	1.60
588	V-Belt, Cir. In. 59 1/2", Out. 61 1 1/4"	1.65
595	V-Belt, Cir. In. 59 3/4", Out. 61 3/4"	1.65
644	V-Belt, Cir. In. 64 1/4", Out. 66 1/4"	1.85

Catalog No.	Description	Price
49-105	V-Belt, Cir. In. 28 1/4", Out. 30"	1.15
49-142	V-Belt, 51 3/4" O.C.	1.45
49-144	V-Belt, 56 3/4" O.C.	1.50
49-152	V-Belt, 36" O.C.	1.15
49-154	V-Belt, 40" O.C.	1.25
49-179	V-Belt, 94" O.C.	3.15

NEW RETRACTABLE CASTER SETS for your Deltashop and other Delta Tools.



Store your Delta power tools in a corner of the utility room, garage or basement, or even keep them in a closet! Roll them out when you use them—roll them back when you've finished. Easily retracted when the machine is in use, gives you the solidity and accuracy of a stationary machine.

Retractable Caster Sets for Delta power tools. See listings under individual machines.

WRENCHES AND ALLEN KEYS

No.	Description	Price
192	Allen Key W-5/32" with 4 3/4" metal handle	\$.35
194	Allen Key W-5/32"	.20
942	3/4" C.I. Box Wrench	.85
949	1 1/4" Forged Open Wrench	1.00
1520	3/8" Hex. closed, 1 1/16" Stamped Open End, 3/8" and 1/2" Shaper Spindle Holes	.45
1521	Allen Key, W-1/4"	.30
1522	Double end 3/16" Forged Open End	.45
1523	5/8" and 1 1/16" double and box wrench	.70
1524	3/16" and 1/8" Stamped Double End Box	.35
1525	3/8" closed, 7/8" Stamped Open End Box	.40
1526	3/16" and 3/16" Stamped Double End Box	.30
1527	3/8" C.I. Box Wrench	.55
1529	1/2" Hex. Socket Wrench	.70
1530	Allen Key, W-1/4"	2.25
1531	Allen Key, W-3/8"	.45
1532	Allen Key, W-1/4"	.35
1533	Allen Key, W-3/32"	.35
1534	Allen Key, W-1/8"	.25
1535	Allen Key, W-3/16"	.25
1536	Allen Key, W-3/16"	.35
1538	5/8" and 3/4" Stamped Double End Box	.35

DELTA Homecraft MOTORS

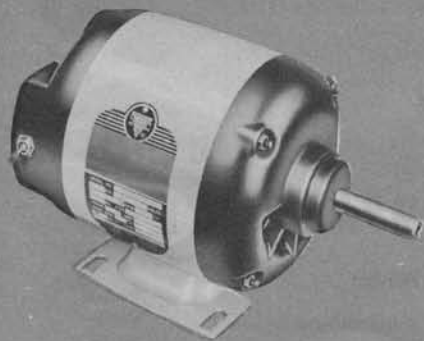

Delta Homecraft power tools are engineered to the highest standards—to make sure that you always obtain peak performance. But even the finest machine cannot operate properly without the right motor.

To make sure you get the best in machine performance, cutting action, speeds and all-around accuracy, always use DELTA-engineered Homecraft motors. The motors recommended for each machine are DELTA-engineered for that machine, are designed to provide that PLUS performance that has made Delta products the finest in the field.

The wide acceptance of Delta Homecraft motors results in high volume production with resulting manufacturing economies that are passed on to you in attractive low prices.

Compare—then buy DELTA!

Cat. No.	H.P.	Volts	Type	Cycles	Speed R.P.M.	Shaft Dia.	Bearings	Switch Cord & Plug	Price
60-013	1/3	115V	Split Phase	60	1725	1/2" Single Shaft	Bronze	Not included *See Note	\$15.95
62-413	1/3	115V	Capacitor Start	60	1725	1/2" Single Shaft	Sealed Ball Bearings	Included	29.95
62-653	1/2	115V	Capacitor Start	60	1725	3/8" Dbl. Shaft with Keyway	Sealed Ball Bearings	Included	36.95
62-253	3/4	115V	Capacitor Start	60	3450	5/8" Dbl. Shaft with Keyway	Sealed Ball Bearings	Included	44.95
62-213	1/2	115V	Capacitor Start	60	3450	1/2" Single Shaft	Sealed Ball Bearings	Cord & Plug Only	39.95

*Order Cat. No. 49-311 Toggle Switch, 8-ft. Rubber Covered Cord and Plug (49-307 and 49-308 in One Package) 3.15

**For reversing motor order Cat. No. 49-316 Reversing Switch 11.50
† Equipped with Thermal overload, Manual Reset button.

The new DELTA Curve Cutting SABER SAW Attachment

For The Deltashop and Delta No. 34-500 Circular Saw

This is one of the most exciting tools developed for do-it-yourself enthusiasts. In a matter of seconds this new attachment converts the Deltashop or the Delta No. 34-500 8" Tilting Arbor Circular Saw to an efficient machine capable of doing intricate curve cutting work. You can mount standard scroll saw accessories such as the sanding attachment and swiss pattern files to do sanding and filing operations. In addition to multiplying the usefulness of the basic circular saw, it offers features unequaled by any comparable curve cutting tool on the market today:

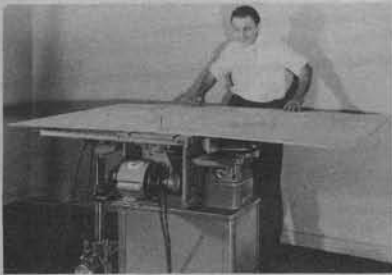

Unlimited curve cutting capacity. You get full use of the big 15 x 22 table surface of the basic circular saw providing a greater working area than in any comparable curve cutting tool.

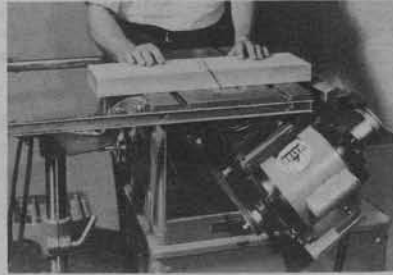

Tilting blade for curved angle cutting. You can use the tilting blade mechanism of the basic saw to tilt the saber blade a full 35°. The table always remains level.



No adjustments for pierced cutting. Since the saber blade is chucked in a lower chuck only, it is a simple matter to move from one opening to another in pierced work.



Easily converted to do sanding and filing. You can mount standard scroll saw accessories such as the sanding attachment and machine files.

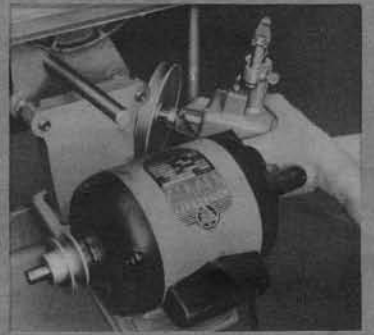

The new saber saw attachment can be installed or removed in seconds—it fits the Deltashop or Delta No. 34-500 Tilting Arbor Circular Saw.

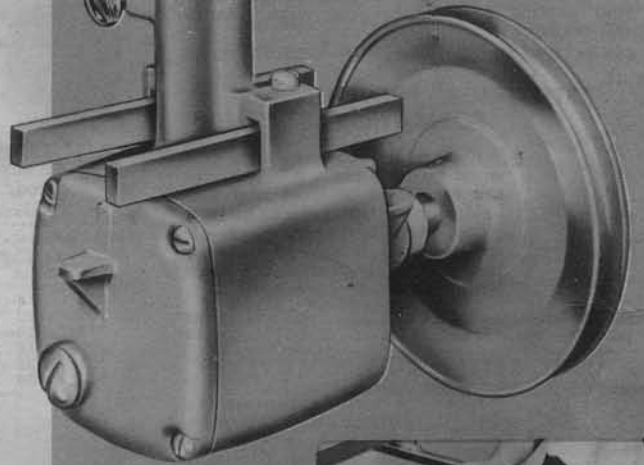

Specifications —
Unlimited cutting capacity . . . thickness of cut, 2" . . . saber blade tilts (with basic saw arbor) 35° . . . depth cutting capacity at 35°, a full 1 3/8".



Catalog Listing . . . Basic Machine—Saber Saw Attachment complete with arbor pulley, two saber blades and blade guides. Wt. 5 1/2 lbs. Catalog No. 40-800 . . . \$14.95

Accessories . . . Instructions with the saber saw show how you can convert your regular table insert for simple saber saw cutting. However, for best results a special table insert should be used. It replaces your present insert and enables you to do sanding and filing in addition to curve cutting. Special table insert. Catalog No. 34-969 . . . \$1.50

For saber blades, machine files, sanding attachment and sleeves, see scroll saw accessories, page 18.

DELTA POWER TOOLS ARE BUILT BY
Rockwell MANUFACTURING COMPANY



400 NORTH LEXINGTON AVENUE, PITTSBURGH 8, PENNSYLVANIA